



Board of Adjustment Staff Report

Meeting Date: December 3, 2020

Agenda Item: 9B

SPECIAL USE PERMIT CASE NUMBER: WSUP20-0014 Red Peak West Cell Tower

BRIEF SUMMARY OF REQUEST: New 40-foot-tall cellular communication tower

STAFF PLANNER: Roger Pelham, MPA, Senior Planner
775.328.3622
rpelham@washoecounty.us

CASE DESCRIPTION

For possible action, hearing, and discussion to approve a special use permit to allow the removal of an existing 15-foot-tall cellular communication tower and the construction and operation of a new 40-foot-tall cellular communication tower.

Applicant: 51 Wireless, LLC
 Property Owner: Desert View Commercial Properties, LLC
 Location: At the top of Red Peak, approximately ¼ mile southeast of the intersection of Sagehen Lane and Carolyn Way
 APN: 502-250-08
 Parcel Size: ±12.63 acres
 Master Plan: Rural
 Regulatory Zone: General Rural (GR)
 Area Plan: Sun Valley
 Citizen Advisory Board: Sun Valley
 Development Code: Authorized in Article 324, Communication Facilities
 Commission District: 3 – Commissioner Jung

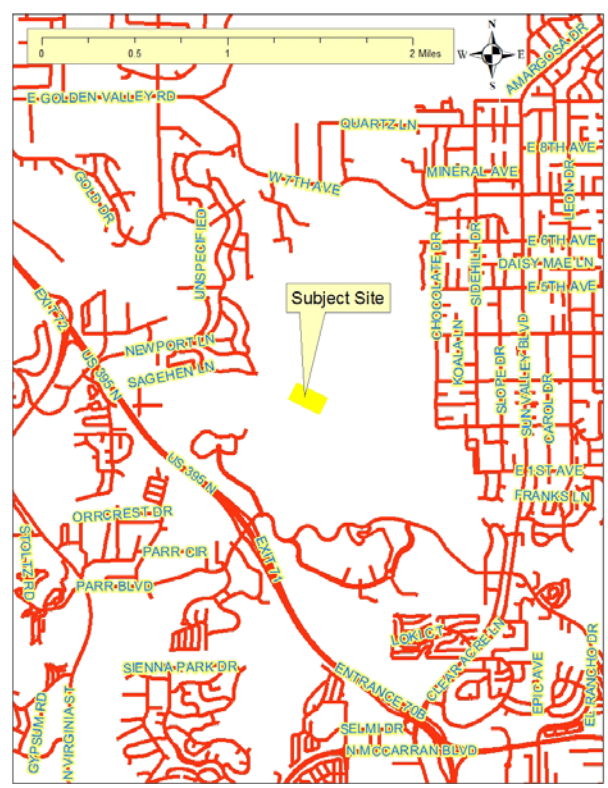

STAFF RECOMMENDATION

APPROVE

APPROVE WITH CONDITIONS

DENY

POSSIBLE MOTION

I move that, after giving reasoned consideration to the information contained in the staff report and information received during the public hearing, the Washoe County Board of Adjustment approve with conditions Special Use Permit Case Number WSUP20-0014 for 51 Wireless, LLC. having made all findings in accordance with Washoe County Code Section 110.810.30 and Section 110.324.75, subject to the conditions contained in Exhibit A to the Staff Report.

Staff Report Contents

Special Use Permit.....3

Vicinity Map.....4

Photo Simulations6

Site Plan Elevation9

Project Evaluation9

Reviewing Agencies12

Recommendation13

Motion13

Appeal Process13

Exhibits Contents

Conditions of ApprovalExhibit A

Agency CommentsExhibit B

Public NoticeExhibit C

Project Application.....Exhibit D

Special Use Permit

The purpose of a special use permit is to allow a method of review to identify any potential harmful impacts on adjacent properties or surrounding areas for uses that may be appropriate within a regulatory zone; and to provide for a procedure whereby such uses might be permitted by further restricting or conditioning them so as to mitigate or eliminate possible adverse impacts. The Board of Adjustment is authorized to issue special use permits under NRS 278.315 and Washoe County Code (WCC) Article 810. Certain notice requirements must be met, which are discussed in this report. In approving the special use permit, the Board must consider and make five Findings of Fact, which are discussed below. [WCC Section 110.810.30] The notice requirements and findings are discussed in this report. The Board of Adjustment is allowed to grant an approval of the special use permit that is subject to Conditions of Approval. Conditions of Approval are requirements that need to be completed during different stages of the proposed project, including conditions prior to permit issuance, prior to obtaining a final inspection and/or certificate of occupancy, prior to issuance of a business license, or ongoing “operational conditions” which must be continually complied with for the life of the project.

Conditions of Approval. The Conditions of Approval for this case are attached to this staff report as Exhibit A and will be included with the Action Order.

Variances. As a part of approval of a special use permit, the Board of Adjustment may also vary standards of the Development Code as they would apply to the Project. [See WCC Section 110.810.20 (e).] In so doing, the Board must make the five findings required for variances as set out in WCC Section 110.804.25.

Special Communications Facility requirements. The proposed facility is a “communications facility” under Article 324 of the County Development Code which imposes specialized requirements and provides that when approving a special use permit, the Board must adopt the three additional findings listed in WCC Section 110.324.75 which are discussed in this staff report.

Special Federal and State Rules The proposed facility is a “personal wireless service facility” protected by federal law (Telecommunications Act of 1996, 47 U.S.C. Section 332 (c) (7)) and state law (NRS 707.550 – 707. 920). Generally, federal and state laws provide that when regulating the placement, construction or modification of wireless facilities:

- We shall not unreasonably discriminate among providers of functionally equivalent services;
- We shall not prohibit or have the effect of prohibiting the provision of personal wireless services;
- We must act within a reasonable time on applications for permits (presumed to be 150 days under FCC “shot clock” rules);
- If we deny a request to place, construct, or modify personal wireless service facilities, we must do so in a separate writing, and the decision must be supported by substantial evidence (evidence that a reasonable mind might accept as adequate to support a conclusion) contained in a written record. State law (NRS 707.585) requires that a decision denying an application must set forth with specificity each ground on which the authority denied the approval of the application, and must describe the documents relied on by the Board in making its decision.
- We may not regulate the placement, construction and modification of personal wireless facilities on the basis of environmental effects of radio frequency emissions to the extent that such facilities comply with FCC regulations concerning such emissions.

The subject property has a regulatory zone of General Rural (GR). Cellular communication towers are permissible in the GR zone subject to approval of a special use permit.

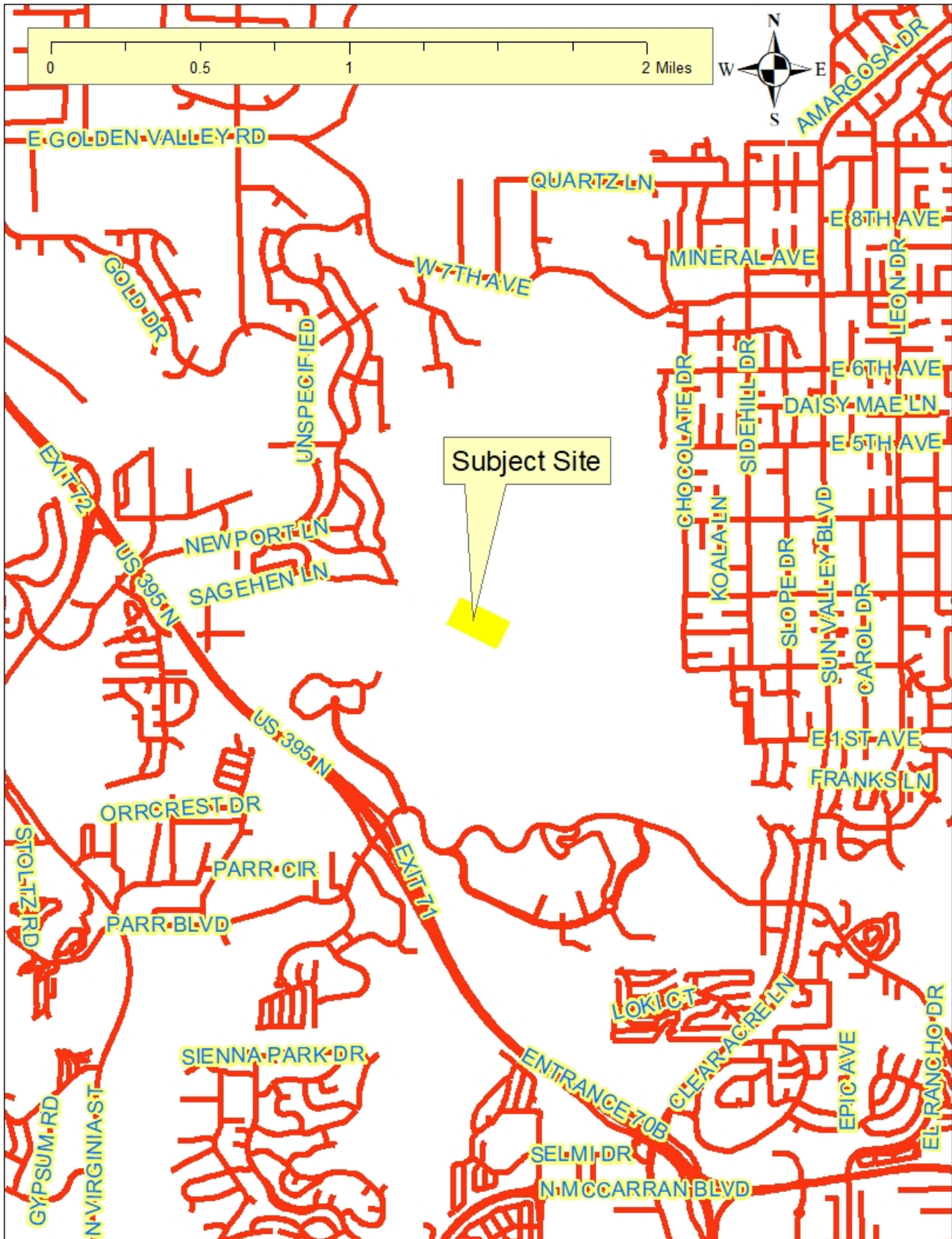

Vicinity Map

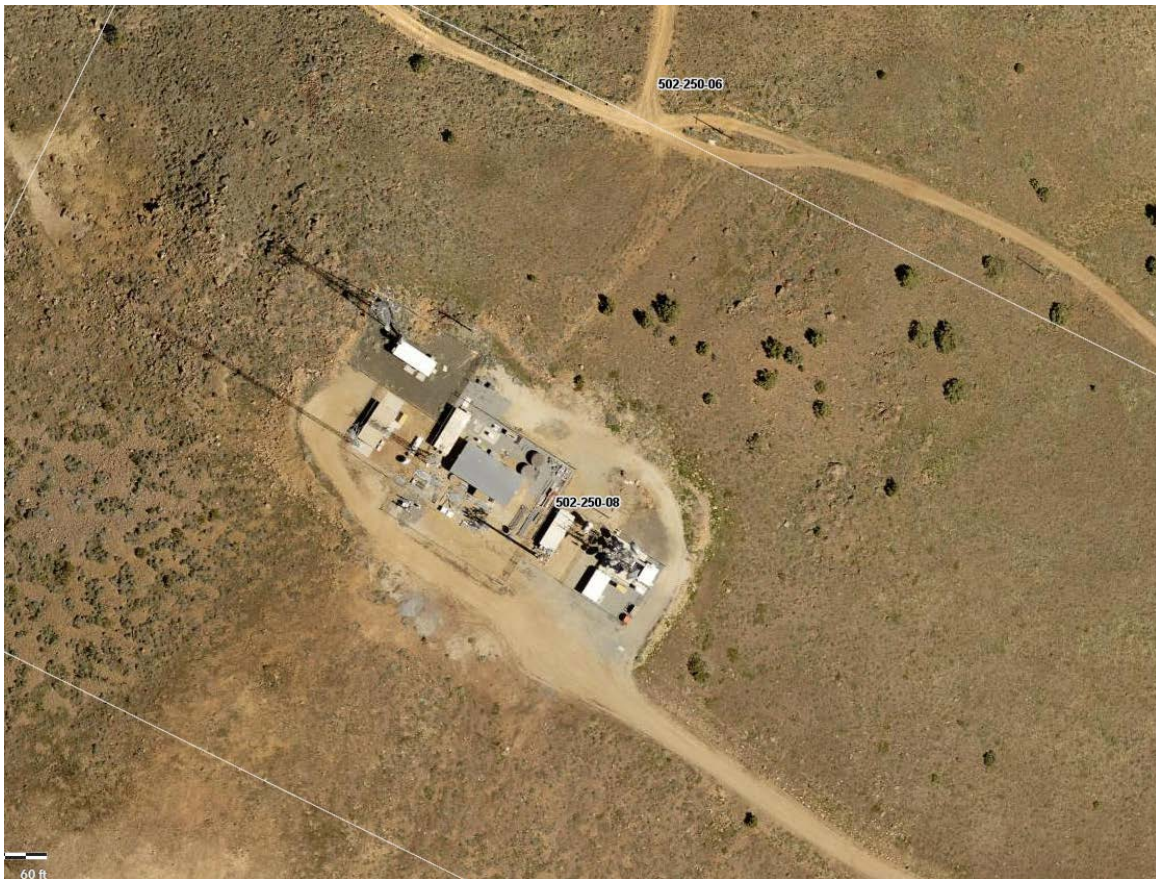

Overhead Photo of Subject Site



Site Photo



view from Ranger Road looking east at site

AdvanceSim
Photo Simulation Solutions
Contact (925) 202-8507

T-Mobile

SC09320A Red Peak West
2000 First Avenue, Sparks, NV
Photosims Produced on 9-11-2020

Existing



Proposed

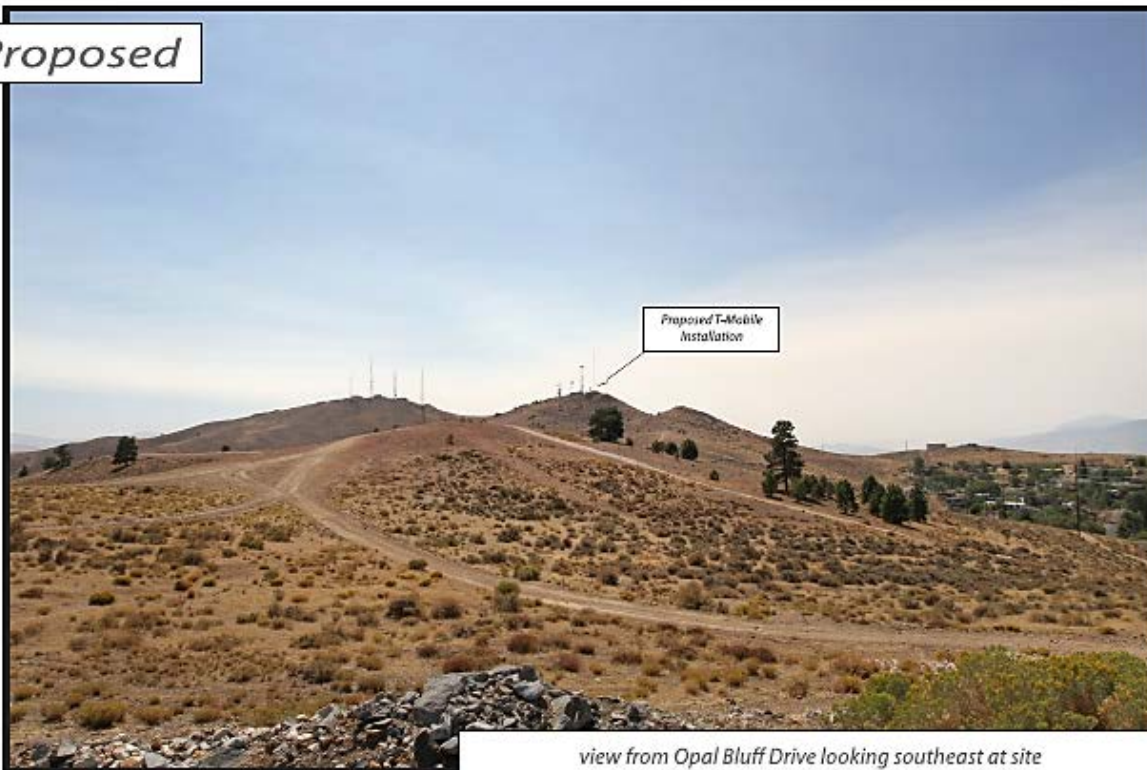

view from Opal Bluff Drive looking southeast at site



SC09320A Red Peak West
2000 First Avenue, Sparks, NV
Photosims Produced on 9-11-2020



Photo Simulations

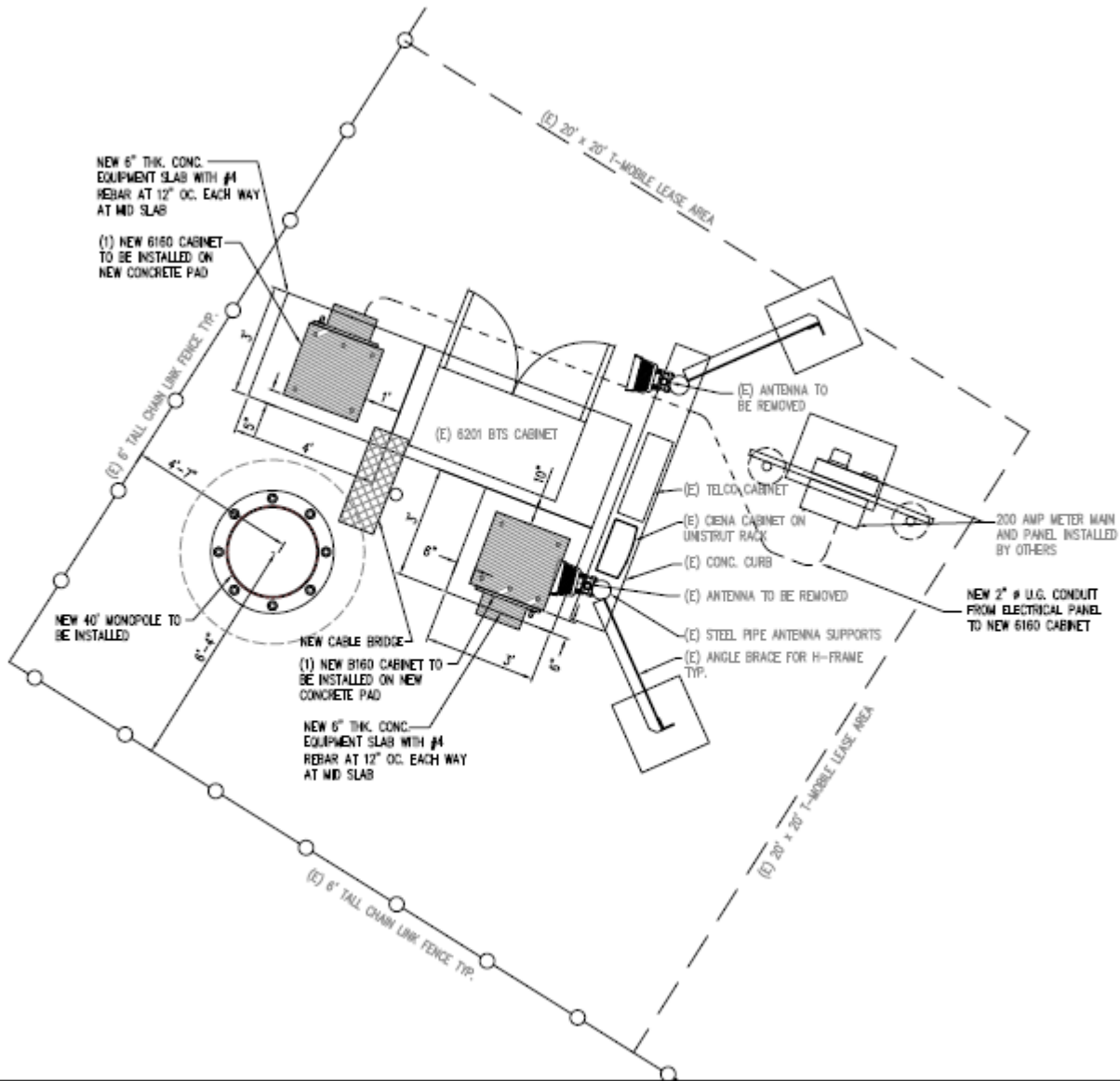

ENLARGED SITE PLAN

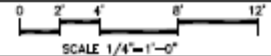

1

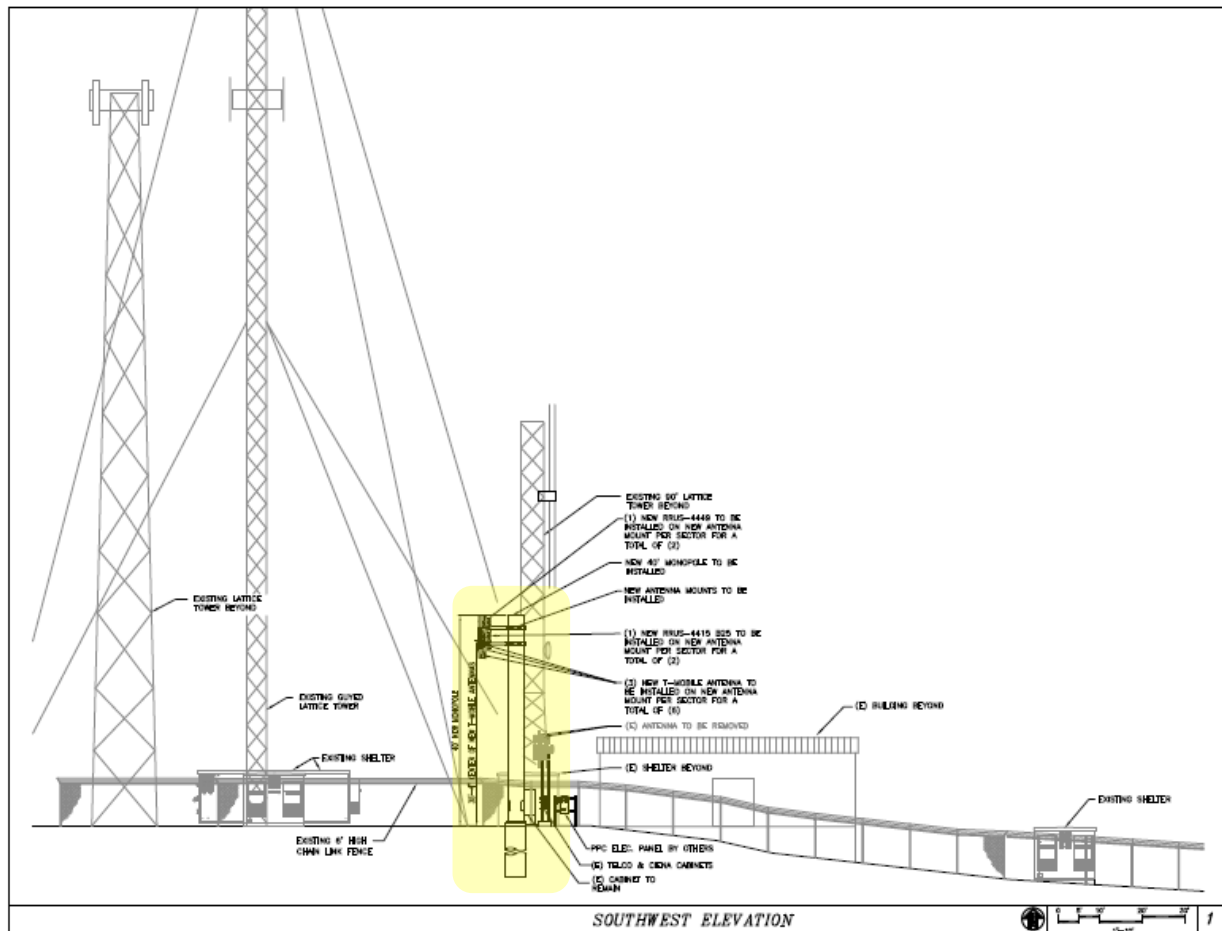

Site Plan Elevation

Project Evaluation

The applicant is requesting to remove an existing 15-foot-tall communication tower and replace it with a new 40-foot-tall communication tower. The proposed tower is a mono-pole type, that will support two antenna arrays. There are several other existing towers that are much taller than the proposed tower. The project site is approximately 1000 feet from the nearest residence and accessed by a series of semi-improved dirt roads.

Use Type:

Section 110.304.25 Commercial Use Types. Commercial use types include the distribution and sale or rental of goods, and the provision of services other than those classified as civic or industrial use types.

- (i) **Communication Facilities** Communication facilities use type refers to establishments primarily engaged in the transmission and/or receiving of electromagnetic waves. Typical uses include television station, radio stations, satellite dishes, antennas and wireless communication facilities. Refer to Article 324, Communication Facilities, for subcategories of communication facilities.

Section 110.324.40 Wireless Communication/Cellular Facilities: Definitions

Wireless communication facilities, including antennas mounted on structures and freestanding monopoles and lattice towers and supporting equipment which are used for the commercial broadcasting/receiving of telecommunication transmissions that are regulated under the

Telecommunications Act of 1996 are a principal use and are classified under the communication facilities use type in Article 304, Use Classification System. The following definitions apply to the regulation of wireless communication facilities contained in this article:

- (a) Antenna An antenna is defined for the purposes of Sections 110.324.40 through 110.324.75 as a device that transmits and/or received an electronic signal for the purposes of facilitating the communication of personal wireless services that has the meaning ascribed to it in 47 U.S.C. §332(c)(7)(C) as that provision existed on July 1, 2003.
- (5) Monopole Mounted Antenna. A monopole mounted antenna means a communications receiving and/or transmitting device that is attached to a ground mounted, free-standing pole that is erected for the purposes of supporting one (1) or more antennas.

The following placement standards by type of antenna shall be complied with notwithstanding the preferred location and type of antenna enumerated in this section:

- (e) Monopole Antenna. The placement of a monopole antenna shall comply with the following criteria:
 - (1) “Antennas shall be allowed in all Rural Residential, Public/Semi-Public Facilities (PSP), General Commercial (GC), Neighborhood Commercial/Office (NC), Tourist Commercial (TC), Industrial (I), Parks and Recreation (PR), and Specific Plan (SP) regulatory zones. Antennas shall be limited to the building standard height for an allowed main structure plus up to ten (10) feet above that height.”
 - (2) Antennas shall be permitted in the General Rural (GR) and Open Space (OS) land use designations (see Open Space limitations within this article) with the placement standards depicted in Table 110.324.50.1, Antenna Placement Standards.

Antenna Height:

The proposed monopole will be placed on a parcel of land zoned General Rural (GR), and the allowable height is 80-feet when it is located no closer than 1000-feet from a residentially zoned parcel or publicly paved right-of-way, whichever is closest. The proposed monopole is more than 1000 feet away from the nearest residence. The applicant is requesting a 40-foot-tall communication tower.

Table 110.324.50.1

ANTENNA PLACEMENT STANDARDS

Design Standards	Distance from Residential Property						
	50'	200'	400'	600'	1,000'	1,500'	2,000'
Distance from Residentially Zoned Property or Public Paved Right of Way (closest adjacent use will be applied)							
Permitted Height of Pole	45'	50'	60'	70'	80'	90'	+100'
Supporting Mechanism for Antenna System	2*	2.5*	3*	4*	5*	6*	+7*

Note: * = Specified number times diameter at base of pole equals allowed supporting mechanism for antenna system diameter.

Source: Washoe County Planning and Building Division

Access/Parking:

No new access or parking spaces will be required, as the facility is an unmanned facility. The applicant anticipates using the existing access roads leading to the tower site, which is unpaved.

Landscaping:

The applicant has indicated that there will be no landscaping due to the site being located within an existing enclosure with approximately 10 other towers. The BOA has the ability to waive or modify standards in accordance with WCC110.810.20 (e) which states, "The Planning Commission, Board of Adjustment or a hearing examiner may take action to approve, approve with conditions, modify, modify with conditions, or deny the special use permit request. The Planning Commission, Board of Adjustment or a hearing examiner **may also vary standards of the Development Code as part of the approval of a special use permit application.** Failure of the Planning Commission, Board of Adjustment or a hearing examiner to hold a public hearing or take action within the time frames provided in this article shall constitute approval of the application." Staff is of the opinion that landscaping is not a benefit at this location.

Visual Impacts:

There are no significant visual impacts likely. This tower is among an existing cluster of towers and is shorter than most of the others. It is unlikely that there will be any discernable visual change.

Radio Frequency and Environmental Impacts:

Under federal law (47 U.S.C. 332 (c) (7) (B) (iv)), if the proposed telecommunications facility complies with FCC regulations, this Board cannot regulate its placement, construction, and modification based on the potential environmental effects of radio frequency emissions. Under state law (NRS 707.575 (4)) the Board "shall not consider the environmental effects of radio frequency emissions" in rendering a decision of approving or denying this special use permit.

Sun Valley Citizen Advisory Board (SVCAB)

The proposed project was sent to the Citizen Advisory Board for their review and comment. The CAB met on October 19, 2020. The CAB expressed no objection to the project and voted to recommend approval. Minutes from that meeting are not available at the writing of this report. Staff will provide those comments at the public hearing. Reviewing Agencies

The following agencies/individuals received a copy of the project application for review and evaluation.

- Washoe County Community Services Department
 - Planning and Building Division
 - Engineering and Capital Projects Division
 - Utilities/Water Rights
 - Parks and Open Spaces
- Washoe County Health District
 - Air Quality Management
 - Vector-Borne Diseases Program
 - Environmental Health Services Division
- Truckee Meadows Fire Protection District
- Regional Transportation Commission
- Washoe-Storey Conservation District

The following is a brief **summary** received of each agency's comments and/or recommended conditions of approval and their contact information. The Conditions of Approval document is attached to this staff report and will be included with the Action Order.

- Truckee Meadows Fire Protection District addressed compliance with Washoe County Code Chapter 60 requirements, including Fire Apparatus Access Roads, Water Supply and Wild-Urban Interface standards, as applicable.

Contact: Dale Way, 775.326.6000, dway@tmfpd.us

REQUIRED FINDINGS

Findings required by WCC Section 110. 810.30 for a Special Use Permit:

1. Consistency. That the proposed use is consistent with the action programs, policies, standards and maps of the Master Plan and the North Valleys Area Plan;

Staff Comment: Staff has reviewed the Master Plan and the Sun Valley Area Plan and has not identified any provisions that are offended by the project.

2. Improvements. That adequate utilities, roadway improvements, sanitation, water supply, drainage, and other necessary facilities have been provided, the proposed improvements are properly related to existing and proposed roadways, and an adequate public facilities determination has been made in accordance with Division Seven of the Development Code;

Staff Comment: The proposed project is in compliance with Division Seven.

3. Site Suitability. That the site is physically suitable a for a telecommunications facility (monopole) for the intensity of such a development;

Staff Comment: The proposed tower is one of several at this same location. The site is suitable.

4. Issuance Not Detrimental. That issuance of the permit will not be significantly detrimental to the public health, safety or welfare; injurious to the property or improvements of adjacent properties; or detrimental to the character of the surrounding area.

Staff Comment: Based on the requirements of the FCC, the "Electromagnetic Frequency (RF) exposure level due to the proposed site is well below the maximum allowable by FCC Regulations. The site fully complies with FCC rules and regulations.

5. Effect on a Military Installation. Issuance of the permit will not have a detrimental effect on the location, purpose or mission of the military installation.

Staff Comment: There is no military installation nearby.

Findings required by Section 110.324.75, for a telecommunications facility:

6. That the communications facility meets all the standards of Sections 110.324.40 through 110.324.60 as determined by the Director of Community Development and/or his/her authorized representative;

Staff Comment: Staff has reviewed all of the standards and conclude that the standards have been met.

7. That public input was considered during the public hearing review process; and

Staff Comment: The Board has heard and considered public comment during the public hearing. Under federal law (47 U.S.C. 332 (c) (7) (B) (iv), if the proposed telecommunications facility complies with FCC regulations, this Board cannot regulate its placement, construction, and modification based on the potential environmental effects of radio frequency emissions. Under state law (NRS 707.575 (4) the Board "shall not consider the environmental effects of radio frequency emissions" in rendering a decision of approving or denying this special use permit.

- 8. That the monopole or lattice tower will not unduly impact the adjacent neighborhoods or the vistas and ridgelines of the County.

Staff Comment: Based on a review of the photographs and drawings in the Staff Report and Application, the proposed monopole will blend with existing built environment of the subject parcel.

Recommendation

After a thorough analysis and review, Special Use Permit Case Number WSUP20-0014 is being recommended for approval with conditions. Staff offers the following motion for the Board's consideration.

Motion

I move that, after giving reasoned consideration to the information contained in the staff report and information received during the public hearing, the Washoe County Board of Adjustment approve with conditions Special Use Permit Case Number WSUP20-0014 for 51 Wireless, LLC. having made all findings in accordance with Washoe County Code Section 110.810.30 and Section 110.324.75, subject to the conditions contained in Exhibit A to the Staff Report.

Appeal Process

Board of Adjustment action will be effective 10 calendar days after the written decision is filed with the Secretary to the Board of Adjustment and mailed to the applicant, unless the action is appealed to the Washoe County Board of County Commissioners, in which case the outcome of the appeal shall be determined by the Washoe County Board of County Commissioners. Any appeal must be filed in writing with the Planning and Building Division within 10 calendar days from the date the written decision is filed with the Secretary to the Board of Adjustment and mailed to the applicant.

Applicant/ Developer:	51 Wireless, LL Attn: Nick Targas 4040 Bonanza Way Loomis, CA 95650
Owner:	Desert View Commercial Properties, LLC Attn: Dave Metts
email:	dmetts@hdiss.net



Conditions of Approval

Special Use Permit Case Number WSUP20-0014

The project approved under Special Use Permit Case Number WSUP20-0014 shall be carried out in accordance with the conditions of approval granted by the Board of Adjustment on December 3, 2020. Conditions of approval are requirements placed on a permit or development by each reviewing agency. These conditions of approval may require submittal of documents, applications, fees, inspections, amendments to plans, and more. These conditions do not relieve the applicant of the obligation to obtain any other approvals and licenses from relevant authorities required under any other act or to abide by all other generally applicable codes.

Unless otherwise specified, all conditions related to the approval of this special use permit shall be met or financial assurance must be provided to satisfy the conditions of approval prior to issuance of a grading or building permit. The agency responsible for determining compliance with a specific condition shall determine whether the condition must be fully completed or whether the applicant shall be offered the option of providing financial assurance. All agreements, easements, or other documentation required by these conditions shall have a copy filed with the County Engineer and the Planning and Building Division of the Washoe County Community Services Department.

Compliance with the conditions of approval related to this special use permit is the responsibility of the applicant, his/her successor in interest, and all owners, assignees, and occupants of the property and their successors in interest. Failure to comply with any of the conditions imposed in the approval of the special use permit may result in the initiation of revocation procedures.

Washoe County reserves the right to review and revise the conditions of approval related to this special use permit should it be determined that a subsequent license or permit issued by Washoe County violates the intent of this approval.

For the purpose of conditions imposed by Washoe County, “may” is permissive and “shall” or “must” is mandatory.

Conditions of approval are usually complied with at different stages of the proposed project. Those stages are typically:

- Prior to permit issuance (i.e., grading permits, building permits, etc.).
- Prior to obtaining a final inspection and/or a certificate of occupancy.
- Prior to the issuance of a business license or other permits/licenses.
- Some “conditions of approval” are referred to as “operational conditions.”

These conditions must be continually complied with for the life of the project or business.

FOLLOWING ARE CONDITIONS OF APPROVAL REQUIRED BY THE REVIEWING AGENCIES. EACH CONDITION MUST BE MET TO THE SATISFACTION OF THE ISSUING AGENCY.

Washoe County Planning and Building Division

1. The following conditions are requirements of the Planning and Building Division of the Washoe County Community Services Department, which shall be responsible for determining compliance with these conditions.

Contact Name – Roger Pelham, 775.328.3622, rpelham@washoecounty.us

- a. The applicant shall demonstrate substantial conformance to the plans approved as part of this special use permit. The Planning and Building Division shall determine compliance with this condition.
- b. The applicant shall submit construction plans, with all information necessary for comprehensive review by Washoe County, and initial building permits shall be issued within two years from the date of approval by Washoe County. The applicant shall complete construction within the time specified by the building permits. Compliance with this condition shall be determined by the Planning and Building Division.
- c. The applicant shall attach a copy of the action order approving this project to all administrative permit applications (including building permits) applied for as part of this special use permit.
- d. A note shall be placed on all construction drawings and grading plans stating:

NOTE

Should any cairn or grave of a Native American be discovered during site development, work shall temporarily be halted at the specific site and the Sheriff's Office as well as the State Historic Preservation Office of the Department of Conservation and Natural Resources shall be immediately notified per NRS 383.170.

- e. Prior to the issuance of a building permit, the applicant shall provide a certification by a professional that the facility complies with Federal Communications Commission (FCC) regulations for Radio Frequency Emissions (RFE).
- f. Prior to the issuance of a building permit the applicant shall record a statement of assurance that the wireless communications facility shall be removed if the use of the facility is discontinued for a period of twelve (12) consecutive months.
- g. All new fencing installed as part of this project shall include slats and provide at least 75% visual screening. Slats shall be of a color to match the surrounding buildings. Fencing materials shall be non-reflective.
- h. The monopole tower shall not exceed 40 feet in maximum height.
- i. Landscaping as generally required under Article 412 of the Development Code is waived with this approval.
- j. The following **operational conditions** shall be required for the life of the project:
 - i. This special use permit shall remain in effect until or unless it is revoked or is inactive for one year.
 - ii. Failure to comply with the conditions of approval shall render this approval null and void. Compliance with this condition shall be determined by the Planning and Building Division.
 - iii. The applicant and any successors shall direct any potential purchaser/operator of the site and/or the special use permit to meet with the Planning and Building Division staff to review conditions of approval prior to the final sale of the site and/or the special use permit. Any subsequent purchaser/operator of the site and/or the special use permit shall notify the Planning and Building Division of the

name, address, telephone number, and contact person of the new purchaser/operator within 30 days of the final sale.

*** End of Conditions ***



Washoe-Storey Conservation District

Bret Tyler Chairmen
Jim Shaffer Treasurer
Cathy Canfield Storey app
Jean Herman Washoe app

1365 Corporate Blvd.
Reno NV 89502
775 857-8500 ext. 131
nevadaconservation.com

October 22, 2020

Washoe County Community Services Department

C/O Roger Pelham, Senior Planner

1001 E Ninth Street, Bldg. A

Reno, NV 89512

R: WSUP20-0014 Red Peak West Cellular Tower

Dear Roger,

In reviewing the special use permit to construct a 40-foot tower, the Conservation District has the following comment.

The District supports the tower paint to match the surrounding hillside color and will require softening the perimeter galvanized fence with brown slats for the same prominence color scheme.

Thank you for providing us the opportunity to review the project that may have impacts on our natural resources.

Sincerely,

Tyler-Shaffer

From: [Program, EMS](#)
To: [Pelham, Roger](#)
Subject: October Agency Review Memo
Date: Wednesday, October 28, 2020 1:20:42 PM

Good afternoon Roger,

The EMS Oversight Program has reviewed Special Use Permit Case #WSUP20-0014 (Red Peak West Cellular Tower), and does not currently have any questions, comments, or concerns regarding this project.

Please let me know if you have any questions.

Vicky

Vicky Olson, MPS, RN

EMS Coordinator | Epidemiology and Public Health Preparedness | Washoe County Health District
volson@washoecounty.us | O: (775) 326 6043 | 1001 E. Ninth St., Bldg. B, Reno, NV 89512

**WASHOE COUNTY
HEALTH DISTRICT**
ENHANCING QUALITY OF LIFE





Roger Pelham, Sr. Planner
Washoe County – Community Services Department
1001 E. Ninth St
Reno, NV 89512
775.328.3622

Re: WSUP20-0014 (Red Peak west Cellular Tower) – Conditions of Approval

Truckee Meadows Fire Protection District (TMFPD)

The following conditions are requirements of the Truckee Meadows Fire Protection District, which shall be responsible for determining compliance with these conditions. Unless otherwise stated, these conditions shall be met prior to the issuance of any building or grading permit or on an ongoing basis (phased development) as determined by TMFPD.

Any future development of a single, multiple, or all parcels will be subject to currently adopted Fire and Wildland-Urban Interface Codes at the time of development on the specific parcel.

Contact Name – Dale Way / Brittany Lemon, 775.326.6000, dway@tmfpd.us / blemon@tmfpd.us

Fire Apparatus Access Roads

1. Fire apparatus access roads shall be in accordance with *International Fire Code* Appendix D and all other applicable requirements of the IFC. (IFC 503.1 / D101.1)
2. Approved fire apparatus access roads shall be required for every facility, building, or portion of a building hereafter constructed or moved into or within the jurisdiction. The fire apparatus access roads shall comply with the requirements of IFC Section 503 and Appendix D and shall extend to within 150 feet of all portions of the facility and all portions of the *exterior walls* of the first story of the building as measured by an *approved* route (as the hose lays around obstructions) around the exterior of the building or facility. (IFC 503.1.1)
3. Fire apparatus access roads shall have an all-weather surface and be capable of supporting the weight of Fire District apparatus (80,000 pounds). (IFC 503.2.3 / D102.1)
4. Fire apparatus access roads shall have a minimum width of 20 feet (with no parking), 26 feet (one side parking), and 32 feet (parking on both sides), exclusive of shoulders, and an unobstructed vertical clearance of not less than 13 feet 6 inches. (IFC 503.2.1 / D103.6.1 / D103.6.2)
5. Where a fire hydrant is located on a fire apparatus access road, the minimum road width shall be 26 feet (7925 mm), exclusive of shoulders (see Figure D103.1). (IFC D103.1)

Truckee Meadows Fire Protection District • 3663 Barron Way, Reno, NV 89511 • tmfpd.us • 775-326-6000



6. Fire apparatus access roads less than the width required for parking on both sides shall be marked and/or signed in accordance with Section 503.3 and Appendix D103.6 to identify such roads or prohibit the obstruction thereof. The means by which fire lanes are designated shall be maintained in a clean and legible condition at all times and be replaced or repaired when necessary to provide adequate visibility. (IFC 503.3 / D103.6)
7. Fire apparatus access roads shall not exceed 10 percent in grade. Angles of approach and angles of departure must not exceed 6 percent for 25 feet before or after the grade change. (IFC D103.2 / 503.2.8)
8. Fire apparatus access roads shall have a minimum inside turning radius of 28 feet, and a minimum outside turning radius of 52 feet. (IFC D103.3)
9. Dead-end fire apparatus access roads in excess of 150 feet shall be provided with width and turnaround provisions in accordance with Table D103.4. (IFC D103.4)
10. Gates across fire apparatus access roads shall comply with Appendix D103.5 and Sections 503.4 and 503.5.
11. Buildings four or more stories or 30 feet in height shall have at least two (2) means of fire apparatus access for each structure. (IFC D104.1)
12. Buildings exceeding 62,000 square feet in area shall have at least two (2) means of fire apparatus access for each structure. (IFC D104.2)
13. Where two (2) fire apparatus access roads are required, they shall be placed a distance apart equal to not less than one half the length of the maximum overall diagonal dimension of the lot or area to be served, measured in a straight line between accesses. (IFC D104.3)
14. Where the vertical distance between the grade plane and the highest roof surface exceeds 30 feet approved aerial fire apparatus access roads shall be provided. (IFC D105.1)
15. When aerial fire apparatus access roads are required, aerial fire apparatus access roads shall have a minimum unobstructed width of 26 feet, exclusive of shoulders, in the immediate vicinity of the building or portion thereof. (IFC D105.2)
16. When aerial fire apparatus access roads are required, one or more of the required access routes meeting this condition shall be located not less than 15 feet and not greater than 30 feet from the building, and shall be positioned parallel to one entire side of the building. The side of the building on which the aerial fire apparatus access road is positioned shall be approved by the *fire code official*. (IFC D105.3)
17. When aerial fire apparatus access roads are required, overhead utility and power lines shall not be located over the aerial fire apparatus access road or between the aerial fire apparatus road and the building. Other obstructions shall be permitted to be placed with the approval of the *fire code official*. (IFC D105.4)



Fire Protection Water Supplies

1. An approved water supply capable of supplying the required fire flow for fire protection shall be provided to premises on which facilities, buildings or portions of buildings are hereafter constructed or moved into or within the jurisdiction. (IFC 507.1)
2. The number of fire hydrants available to a building shall be not less than the minimum specified in Table C102.1. (IFC C102.1)
3. Fire hydrant systems shall comply with Washoe County Standard Detail W-23 and IFC Sections 507.5.1 through 507.5.6. (IFC 507.5 / Washoe County Code)
4. Fire hydrants must be spaced at a maximum separation of 500 feet along the required apparatus access lane in residential areas and 1,000 feet where not required for structures to provide for transportation hazards. Hydrant spacing may be increased by 125 feet if all structures within the development are provided with fire sprinkler protection. There is no allowable increase for hydrants installed for transportation hazards. (IFC Table C102.1)
5. In developments with R-3 occupancies, where a portion of the facility or building hereafter constructed or moved into or within the jurisdiction is more than 600 feet (122 m) from a hydrant on a fire apparatus access road, as measured by an approved route around the exterior of the facility or building, on-site fire hydrants and mains shall be provided where required by the fire code official. (IFC 507.5.1)
6. Unobstructed access to fire hydrants shall be maintained at all times. The fire department shall not be deterred or hindered from gaining immediate access to fire protection equipment or fire hydrants. (IFC 507.5.4)
7. A 3-foot minimum clear space shall be maintained around the circumference of fire hydrants, as measured from the furthest edge of a fire hydrant in any direction. (IFC 507.5.5)
8. Fire hydrants shall not be located within six feet of a driveway, power pole, or light standard. (IFC 507.5.6)
9. Fire hydrants shall be located adjacent to apparatus access lanes and a minimum of four feet and a maximum of seven feet from back of curb. Provide a detail on the plans. (IFC 507.5.6)
10. Fire hydrants shall have a concrete pad around the base in accordance with Washoe County Standard Detail W-23.





International Wildland-Urban Interface Code

1. All parcels located in other than a Low Hazard WUI Rating shall comply with all provisions of the IWUI as adopted and amended by TMFPD and Washoe County Building.
2. The IWUI Fire Hazard designation for your project is available on the provided Washoe Regional Mapping System link. (<https://gis.washoecounty.us/wrms/firehazard>). After you have found your property using the address search feature, the color of the background area will indicate your wildland fire risk.
3. When you have determined your Fire Risk Rating use the link provided, to determine the *IWUIC* construction and defensible space requirements. (https://www.washoecounty.us/building/Files/Files/2012%20WUI%20CODE%20GUIDE_rev%2011-25-13.pdf).



From: [Kirschenman, Sophia](#)
To: [Pelham, Roger](#)
Subject: Parks Comments Re: WSUP20-0014
Date: Monday, October 26, 2020 1:38:39 PM
Attachments: [Outlook-1kat4vhw.png](#)
[Outlook-smzeauk4.png](#)
[Outlook-cnxkhqpm.png](#)
[Outlook-3fxhtkir.png](#)
[Outlook-q23lhkiq.png](#)

Hi Roger,

I've reviewed WSUP20-0014 (Red Peak West Cell Tower) on behalf of Washoe County Regional Parks and Open Space and have no comments or conditions. We do have plans to develop a trail system on Red Hill, but there are no official trails out there at this point. Those towers definitely detract from the view in my opinion, but there's not much we can do about that at this point. I'd require some sort of stealth pole, but it would likely look out of place and would be inconsistent with our past requirements. Anyway, let me know if you have any comments or questions.

Thank you,



Please tell us how we did by taking a quick [survey](#).

Sophia Kirschenman

Park Planner | Community Services Department

775.328.3623 | 1001 E. 9th Street, Reno, NV 89512



Please consider the environment before printing this e-mail.



WASHOE COUNTY
COMMUNITY SERVICES
INTEGRITY COMMUNICATION SERVICE

P.O. Box 11130
Reno, Nevada 89520-0027
Phone: (775) 328-3600
Fax: (775) 328-3699

October 21, 2020

TO: Roger Pelham, MPA, Senior Planner, CSD, Planning & Development Division
FROM: Vahid Behmaram, Water Rights & Water Resources Consultant, CSD
SUBJECT: Special Use Permit Case Number WSUP20-0014 (Red Peak West Cellular Tower)

Project description:

The applicant is proposing to approve a special use permit to allow the removal of an existing 15-foot tall cellular communication tower and the construction and operation of a new 40-foot-tall cellular communication tower.

Project located at the top of Red Peak, approximately ¼ mile southeast of the intersection of Sagehen Lane and Carolyn Way, Assessor's Parcel Number: 502-250-08.

The Community Services Department (CSD) recommends approval of this project with the following Water Rights comments & conditions:

The application indicates no water or sewer utilities at the existing site and suggests no water demand associated with the proposed project.

There are no conditions of approval for this project.





WASHOE COUNTY
COMMUNITY SERVICES DEPARTMENT
Engineering and Capital Projects

1001 EAST 9TH STREET
RENO, NEVADA 89512
PHONE (775) 328-3600
FAX (775) 328.3699

Date: October 29, 2020

To: Roger Pelham, Senior Planner

From: Leo Vesely, P.E., Licensed Engineer

Re: Special Use Permit Case **WSUP20-0014 – Red Peak West Cell Tower**
APN 502-250-08

GENERAL PROJECT DISCUSSION

Washoe County Engineering staff has reviewed the above referenced application. The Special Use Permit is for the approval to allow the removal of an existing 15-foot-tall cellular communication tower and the construction and operation of a new 40-foot-tall cellular communication tower. There are no Engineering Division related comments or conditions of approval to supplement applicable County Code and based upon our review of the site and the application prepared by 51 Wireless for T-Mobile Wireless.

For questions related to sections below, please see the contact name provided.

GENERAL CONDITIONS

Contact Information: Leo Vesely, P.E. (775) 328-2313

1. No comments.

DRAINAGE (COUNTY CODE 110.416, 110.420, and 110.421)

Contact Information: Leo Vesely, P.E. (775) 328-2313

1. No comments.

TRAFFIC AND ROADWAY (COUNTY CODE 110.436)

Contact Information: Mitch Fink, P.E. (775) 328-2050

1. No comments.

UTILITIES (County Code 422 & Sewer Ordinance)

Contact Information: Tim Simpson, P.E. (775) 954-4648

1. No comments.]

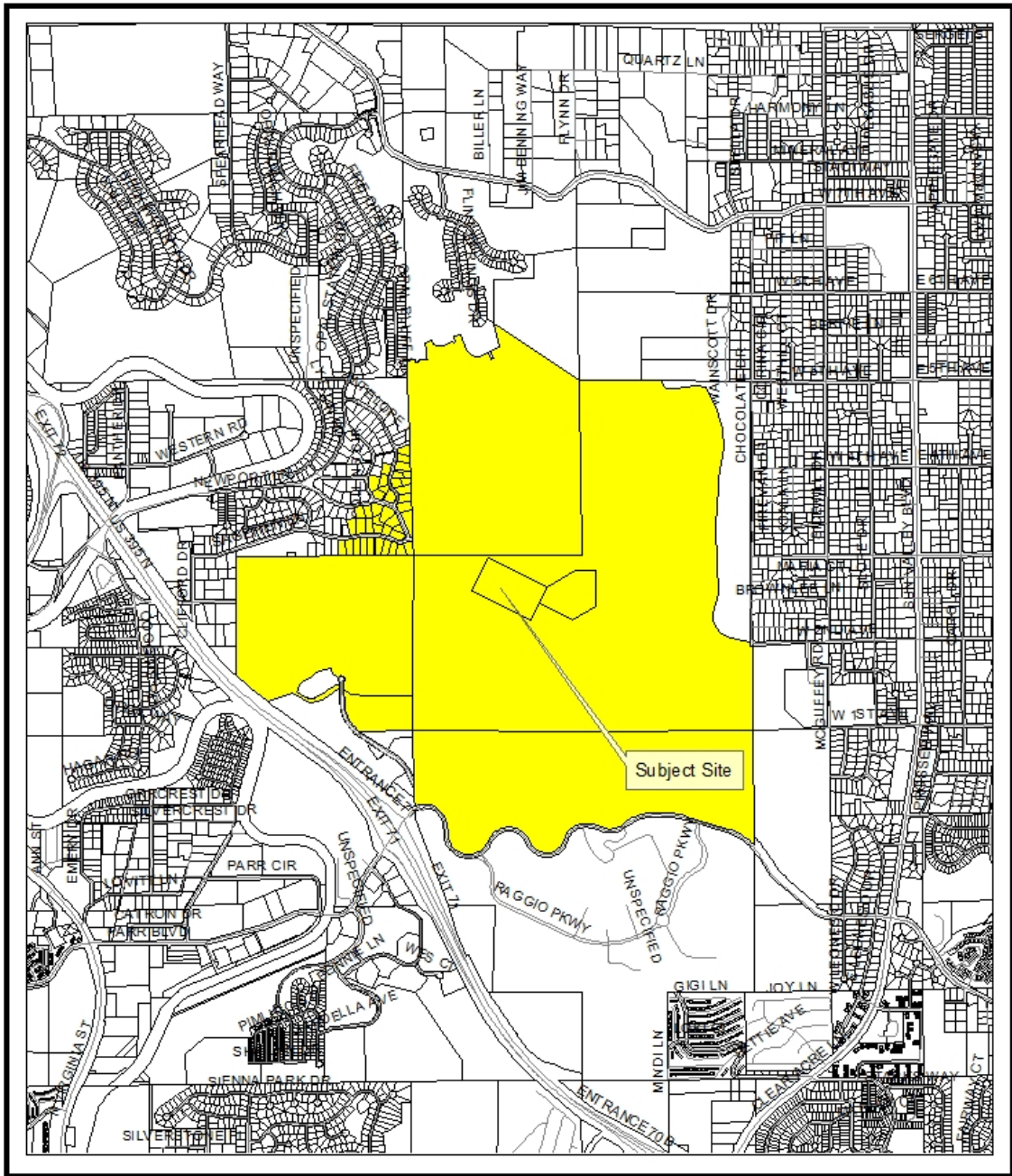

Mailing and Vicinity Map

WSUP20-0014 Red Peak West Cell Tower
 48 parcels selected at 1500 feet

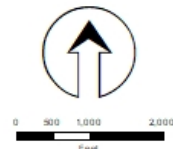

Community Services
 Department

WASHOE COUNTY
 NEVADA

1501 E. Ninth St.
 Reno, Nevada 89512 (775) 328-3800

Source: Planning and Building Division

Path: P:\ArcGIS\Templates\FacMap\Map_vicinity_mailing_map_2019.mxd

Date: 10/12/2020

WSUP20-0014 Exhibit D

Washoe County Development Application

Your entire application is a public record. If you have a concern about releasing personal information, please contact Planning and Building staff at 775.328.6100.

Project Information		Staff Assigned Case No.: _____	
Project Name: SC009320A (Red Peak West)			
Project Description: Remove and replace existing 15' T-Mobile tower with a new 40' monopole. Install (6) new antennas on tower and install (4) new radios on new tower.			
Project Address: 2000 First Avenue, Sparks, NV 89431			
Project Area (acres or square feet): 20' x 20' (400 square feet)			
Project Location (with point of reference to major cross streets AND area locator): 2000 W First Ave and McGuffey Road			
Assessor's Parcel No.(s):	Parcel Acreage:	Assessor's Parcel No.(s):	Parcel Acreage:
502-250-08	12.63		
Indicate any previous Washoe County approvals associated with this application: Case No.(s).			
Applicant Information (attach additional sheets if necessary)			
Property Owner: Desert View Commercial Properties, LLC		Professional Consultant:	
Name: Dave Metts		Name:	
Address:		Address:	
Zip:		Zip:	
Phone: 775-315-6319		Phone:	
Fax:		Fax:	
Email: dmetts@hdiss.net		Email:	
Cell: 775-315-6319		Cell:	
Other:		Other:	
Contact Person: Dave Metts		Contact Person:	
Applicant/Developer: 51 Wireless, LLC.		Other Persons to be Contacted:	
Name: Nick Tagas		Name:	
Address: 4040 Bonanza Way		Address:	
Loomis, CA		Zip:	
Zip: 95650		Zip:	
Phone: 916-990-1446		Phone:	
Fax:		Fax:	
Email: Nick.Tagas@51wireless.net		Email:	
Cell: 916-990-1446		Cell:	
Other:		Other:	
Contact Person: Nick Tagas		Contact Person:	
For Office Use Only			
Date Received:	Initial:	Planning Area:	
County Commission District:		Master Plan Designation(s):	
CAB(s):		Regulatory Zoning(s):	

December 2018

Special Use Permit Application Supplemental Information

(All required information may be separately attached)

1. What is the project being requested?

To remove an existing 15' tall tower owned by T-Mobile within an existing 20' x 20' compound leased by T-Mobile and replace it with a new 40' monopole. 6 new antennas and 4 new radios will be installed on the new tower once it is constructed.

2. Provide a site plan with all existing and proposed structures (e.g. new structures, roadway improvements, utilities, sanitation, water supply, drainage, parking, signs, etc.)

See attached plan set date 8-6-2020

3. What is the intended phasing schedule for the construction and completion of the project?

May 2021 or sooner based on weather conditions. Construction will take approx 12 - 14 weeks.

4. What physical characteristics of your location and/or premises are especially suited to deal with the impacts and the intensity of your proposed use?

This 12 acre parcel has approx 10 existing cellular and communication towers on this peak. There already exists an improved access road leading up to the site

5. What are the anticipated beneficial aspects or affects your project will have on adjacent properties and the community?

Improved 4G LTE coverage and capacity for T-Mobile customers living in Washoe County. In-building, outdoor, as well as in transit coverage will be greatly enhanced. This tower upgrade will improve a significant coverage and capacity gap in this area for T-Mobile and their customers.

6. What are the anticipated negative impacts or affect your project will have on adjacent properties? How will you mitigate these impacts?

None. This area on Red Peak is already encumbered with multiple cell towers ranging in heights exceeding 60 - 90 feet. T-Mobile's tower will be well below the heights of the other existing towers. Also due to the remoteness of this location will have no negative impacts on nearby commercial and residential parcels.

7. Provide specific information on landscaping, parking, type of signs and lighting, and all other code requirements pertinent to the type of use being purposed. Show and indicate these requirements on submitted drawings with the application.

No landscaping is required. This tower sits on a mountain top ridge with an already improved gravel driveway leading up to the site with sufficient parking for technicians and crews who might need to upgrade, operate, or otherwise inspect the facility(s).

8. Are there any restrictive covenants, recorded conditions, or deed restrictions (CC&Rs) that apply to the area subject to the special use permit request? (If so, please attach a copy.)

<input type="checkbox"/> Yes	<input checked="" type="checkbox"/> No
------------------------------	--

9. Utilities:

a. Sewer Service	N/A
b. Electrical Service	N/A
c. Telephone Service	N/A
d. LPG or Natural Gas Service	N/A
e. Solid Waste Disposal Service	N/A
f. Cable Television Service	N/A
g. Water Service	N/A

For most uses, Washoe County Code, Chapter 110, Article 422, Water and Sewer Resource Requirements, requires the dedication of water rights to Washoe County. Please indicate the type and quantity of water rights you have available should dedication be required.

h. Permit #		acre-feet per year	
i. Certificate #		acre-feet per year	
j. Surface Claim #		acre-feet per year	
k. Other #		acre-feet per year	

Title of those rights (as filed with the State Engineer in the Division of Water Resources of the Department of Conservation and Natural Resources).

Intentionally left blank.

10. Community Services (provided and nearest facility):

a. Fire Station	Reno Fire Department Station 10 (5250 N Virginia Street)
b. Health Care Facility	West Hills Hospital (1240 E 9th Street)
c. Elementary School	Lois Allen Elementary School (5155 McGuffey Road)
d. Middle School	Desert Skies Middle School (7550 Donatello Drive)
e. High School	North Valleys High School (1470 E Golden Valley Road)
f. Parks	Panther Valley Park (400 Western Road)
g. Library	TMCC Elizabeth Sturm Library (7000 Dandini Road)
h. Citifare Bus Stop	North Virginia Street and E Parr Boulevard

**Special Use Permit Application
for Grading**

Supplemental Information

(All required information may be separately attached)

1. What is the purpose of the grading?

Minor grading for new tower foundation.

2. How many cubic yards of material are you proposing to excavate on site?

TBD

3. How many square feet of surface of the property are you disturbing?

400 sq. ft.

4. How many cubic yards of material are you exporting or importing? If none, how are you managing to balance the work on-site?

TBD

5. Is it possible to develop your property without surpassing the grading thresholds requiring a Special Use Permit? (Explain fully your answer.)

Again amount of grading TBD but very minor grading as area is already improved.

6. Has any portion of the grading shown on the plan been done previously? (If yes, explain the circumstances, the year the work was done, and who completed the work.)

Yes. Entire area is a graded and improved cell tower farm with multiple towers on this property.

7. Have you shown all areas on your site plan that are proposed to be disturbed by grading? (If no, explain your answer.)

Yes.

8. Can the disturbed area be seen from off-site? If yes, from which directions and which properties or roadways?

No.

9. Could neighboring properties also be served by the proposed access/grading requested (i.e. if you are creating a driveway, would it be used for access to additional neighboring properties)?

No.

10. What is the slope (horizontal/vertical) of the cut and fill areas proposed to be? What methods will be used to prevent erosion until the revegetation is established?

TBD

11. Are you planning any berms?

Yes	No <input checked="" type="checkbox"/>	If yes, how tall is the berm at its highest?
-----	--	--

12. If your property slopes and you are leveling a pad for a building, are retaining walls going to be required? If so, how high will the walls be and what is their construction (i.e. rockery, concrete, timber, manufactured block)?

N/A

13. What are you proposing for visual mitigation of the work?

N/A

14. Will the grading proposed require removal of any trees? If so, what species, how many and of what size?

No.

15. What type of revegetation seed mix are you planning to use and how many pounds per acre do you intend to broadcast? Will you use mulch and, if so, what type?

N/A

16. How are you providing temporary irrigation to the disturbed area?

N/A

17. Have you reviewed the revegetation plan with the Washoe Storey Conservation District? If yes, have you incorporated their suggestions?

N/A

18. Are there any restrictive covenants, recorded conditions, or deed restrictions (CC&Rs) that may prohibit the requested grading?

Yes	No <input checked="" type="checkbox"/>	If yes, please attach a copy.
-----	--	-------------------------------

**Special Use Permit Application for Stables
Supplemental Information**

(All required information may be separately attached)

1. What is the maximum number of horses to be boarded, both within stables and pastured?

2. What is the maximum number of horses owned/maintained by the owner/operator of the project, both within stables and pastured?

3. List any ancillary or additional uses proposed (e.g., tack and saddle sales, feed sales, veterinary services, etc.). Only those items that are requested may be permitted.

4. If additional activities are proposed, including training, events, competition, trail rides, fox hunts, breaking, roping, etc., only those items that are requested may be permitted. Clearly describe the number of each of the above activities which may occur, how many times per year and the number of expected participants for each activity.

5. What currently developed portions of the property or existing structures are going to be used with this permit?

6. To what uses (e.g., restrooms, offices, managers living quarters, stable area, feed storage, etc.) will the barn be put and will the entire structure be allocated to those uses? (Provide floor plans with dimensions).

7. Where are the living quarters for the operators of the stables and where will employees reside?

8. How many improved parking spaces, both on-site and off-site, are available or will be provided? (Please indicate on site plan.) Have you provided for horse trailer turnarounds?

9. What are the planned hours of operation?

10. What improvements (e.g. new structures including the square footage, roadway/driveway improvements, utilities, sanitation, water supply, drainage, parking, signs, etc.) will have to be constructed or installed and what is the projected time frame for the completion of each?

11. What is the intended phasing schedule for the construction and completion of the project?

12. What physical characteristics of your location and/or premises are especially suited to deal with the impacts and the intensity of your proposed use?

13. What are the anticipated beneficial aspects or affects your project will have on adjacent properties and the community?

14. What are the adverse impacts upon the surrounding community (including traffic, noise, odors, dust, groundwater contamination, flies, rats, mice, etc.) and what will you do to minimize the anticipated negative impacts or effects your project will have on adjacent properties?

15. Please describe operational parameters and/or voluntary conditions of approval to be imposed on the administrative permit to address community impacts.

16. What types of landscaping (e.g. shrubs, trees, fencing, painting scheme, etc.) are proposed? (Please indicate location on site plan.)

--

17. What type of signs and lighting will be provided? On a separate sheet, show a depiction (height, width, construction materials, colors, illumination methods, lighting intensity, base landscaping, etc.) of each sign and the typical lighting standards. (Please indicate location of signs and lights on site plan.)

--

18. Are there any restrictive covenants, recorded conditions, or deed restrictions (CC&Rs) that apply to the area subject to the administrative permit request? (If so, please attach a copy.)

<input type="checkbox"/> Yes	<input type="checkbox"/> No
------------------------------	-----------------------------

19. Community Sewer

<input type="checkbox"/> Yes	<input type="checkbox"/> No
------------------------------	-----------------------------

20. Community Water

<input type="checkbox"/> Yes	<input type="checkbox"/> No
------------------------------	-----------------------------

Washoe County Treasurer
 P.O. Box 30039, Reno, NV 89520-3039
 ph: (775) 328-2510 fax: (775) 328-2500
 Email: tax@washoecounty.us

Washoe County Treasurer
 Tammi Davis

Bill Detail

[Back to Account Detail](#)

[Change of Address](#)

[Print this Page](#)

Washoe County Parcel Information

Parcel ID	Status	Last Update
50225008	Active	8/13/2020 1:41:08 AM
Current Owner: DESERT VIEW COMMERCIAL PROPERTIES LLC 1032 DUCK HILL RD WASHOE VALLEY, NV 89704		SITUS: 2000 W 1ST AVE WASHOE COUNTY NV
Taxing District 4000	Geo CD:	
Legal Description		
Township 20 Section Lot 3 Block Range 19 SubdivisionName _UNSPECIFIED		

Installments

Period	Due Date	Tax Year	Tax	Penalty/Fee	Interest	Total Due
INST 1	8/17/2020	2020	\$2,241.42	\$0.00	\$0.00	\$2,241.42
INST 2	10/5/2020	2020	\$2,241.39	\$0.00	\$0.00	\$2,241.39
INST 3	1/4/2021	2020	\$2,241.38	\$0.00	\$0.00	\$2,241.38
INST 4	3/1/2021	2020	\$2,241.38	\$0.00	\$0.00	\$2,241.38
Total Due:			\$8,965.57	\$0.00	\$0.00	\$8,965.57

Tax Detail

	Gross Tax	Credit	Net Tax
State of Nevada	\$470.38	\$0.00	\$470.38
Truckee Meadows Fire Dist	\$1,494.16	\$0.00	\$1,494.16
Washoe County	\$3,850.80	\$0.00	\$3,850.80
Washoe County Sc	\$3,150.20	\$0.00	\$3,150.20
TRUCKEE MDWS/SUN VALLEY WATER BASIN	\$0.03	\$0.00	\$0.03
Total Tax	\$8,965.57	\$0.00	\$8,965.57

Payment History

No Payment Records Found

Pay By Check

Please make checks payable to:
WASHOE COUNTY TREASURER

Mailing Address:
 P.O. Box 30039
 Reno, NV 89520-3039

Overnight Address:
 1001 E. Ninth St., Ste D140
 Reno, NV 89512-2845

Change of Address

All requests for a mailing address change must be submitted in writing, including a signature (unless using the online form).

To submit your address change online [click here](#)

Address change requests may also be faxed to: (775) 328-3642

Address change requests may also be mailed to: Washoe County Assessor
 1001 E 9th Street
 Reno, NV 89512-2845

The Washoe County Treasurer's Office makes every effort to produce and publish the most current and accurate information possible. No warranties, expressed or implied, are provided for the data herein, its use, or its interpretation. If you have any questions, please contact us at (775) 328-2510 or tax@washoecounty.us

This site is best viewed using Google Chrome, Internet Explorer 11, Mozilla Firefox or Safari.

GENERAL NOTES

- DRAWINGS ARE NOT TO BE SCALED. WRITTEN DIMENSIONS TAKE PRECEDENCE. DIMENSIONS ARE TO BE SHOWN ON DRAWINGS UNLESS OTHERWISE NOTED. THE CONTRACTOR'S SCOPE OF WORK SHALL INCLUDE FURNISHING ALL MATERIALS, EQUIPMENT, LABOR, AND ANYTHING ELSE DEEMED NECESSARY TO COMPLETE INSTALLATIONS AS DESCRIBED HEREIN.
- PRIOR TO THE SUBMISSION OF BIDS, THE CONTRACTORS INVOLVED SHALL VISIT THE JOB SITE AND FAMILIARIZE THEMSELVES WITH ALL CONDITIONS AFFECTING THE (E) PROJECT, WITH THE CONSTRUCTION AND CONTRACT DOCUMENTS. FIELD CONDITIONS AND CONFIRM THAT THE PROJECT MAY BE ACCOMPLISHED AS SHOWN PRIOR TO PROCEEDING WITH CONSTRUCTION. ANY DISCREPANCIES, OMISSIONS, OR ERRORS ARE TO BE BROUGHT TO THE ATTENTION OF THE ARCHITECT/ENGINEER.
- THE GENERAL CONTRACTOR SHALL RECEIVE WRITTEN AUTHORIZATION TO PROCEED WITH CONSTRUCTION PRIOR TO STARTING WORK ON ANY ITEM NOT CLEARLY DENIED BY THE CONSTRUCTION DRAWINGS/ CONTRACT DOCUMENTS.
- THE CONTRACTOR SHALL SUPERVISE AND DIRECT THE PROJECT DESCRIBED HEREIN. THE CONTRACTOR SHALL BE SOLELY RESPONSIBLE FOR ALL CONSTRUCTION MEANS, METHODS, TECHNIQUES, SEQUENCES AND PROCEDURES AND FOR COORDINATING ALL PORTIONS OF THE WORK UNDER THE CONTRACT.
- THE CONTRACTOR SHALL INSTALL ALL EQUIPMENT AND MATERIALS ACCORDING TO MANUFACTURER'S/ VENDOR'S SPECIFICATIONS UNLESS NOTED OTHERWISE OR WHERE LOCAL CODES OR ORDINANCES TAKE PRECEDENCE.
- ALL WORK PERFORMED ON PROJECT AND MATERIALS INSTALLED SHALL BE IN STRICT ACCORDANCE WITH ALL APPLICABLE CODES, REGULATIONS, AND ORDINANCES. CONTRACTOR SHALL GIVE ALL NOTICES AND COMPLY WITH ALL LAWS, ORDINANCES, RULES, REGULATIONS AND LAWFUL ORDERS OF ANY PUBLIC AUTHORITY, MUNICIPAL AND UTILITY COMPANY SPECIFICATIONS, AND LOCAL AND STATE JURISDICTIONAL CODES BEARING ON THE PERFORMANCE OF THE WORK.
- GENERAL CONTRACTOR SHALL PROVIDE AT THE PROJECT SITE A FULL SET OF CONSTRUCTION DOCUMENTS UPDATED WITH THE LATEST REVISIONS AND ALL CITY PARTICIPATIONS FOR THE USE BY ALL PERSONNEL INVOLVED WITH THE PROJECT.
- THE STRUCTURAL COMPONENTS OF THIS PROJECT SITE/ FACILITY ARE NOT TO BE ALTERED BY THIS CONSTRUCTION PROJECT UNLESS NOTED OTHERWISE.
- DETAILS INCLUDED HEREIN ARE INTENDED TO SHOW END RESULT OF DESIGN. MINOR MODIFICATIONS MAY BE REQUIRED TO SUIT JOB CONDITIONS OR SITUATIONS, AND SUCH MODIFICATIONS SHALL BE INCLUDED AS PART OF THE SCOPE OF WORK.
- SEAL PENETRATIONS THROUGH FIRE-RATED AREAS WITH U.L. LISTED OR FIRE MARSHALL APPROVED MATERIALS IF APPLICABLE TO THIS FACILITY AND OR PROJECT SITE.
- PROVIDE A PORTABLE FIRE EXTINGUISHER WITH A RATING OF NOT LESS THAN 2-A OR A BURNING 75' FEET TRAVEL DISTANCE TO ALL PORTIONS OF THE PROJECT AREA DURING CONSTRUCTION.
- THE CONTRACTOR SHALL MAKE NECESSARY PROVISIONS TO PROTECT EXISTING IMPROVEMENTS, BASEMENTS, PAVING, CURBING, ETC. DURING CONSTRUCTION. CONTRACTOR SHALL PROTECT EXISTING UTILITIES AND SHALL BE RESPONSIBLE FOR ANY DAMAGE THAT MAY HAVE OCCURRED DUE TO CONSTRUCTION ON OR ABOUT THE PROPERTY.
- CONTRACTOR SHALL SEE TO IT THAT GENERAL WORK AREA IS KEPT CLEAN AND HAZARD FREE DURING CONSTRUCTION AND DISPOSE OF ALL DIRT, DEBRIS, AND WASTE MATERIALS FROM THE PROJECT AREA IN AN APPROPRIATE MANNER. CLEAN UP AND REMOVE ALL PROPERTY, PREMISES SHALL BE LEFT IN CLEAN CONDITION AND FREE FROM PAINT SPOTS, DUST, OR SMUDGES OF ANY NATURE.
- THE ARCHITECTS/ENGINEERS HAVE MADE EVERY EFFORT TO SET FORTH IN CONSTRUCTION DOCUMENTS ALL REQUIREMENTS AND SPECIFICATIONS THAT THE CONTRACTORS PROVIDING THE JOB ARE UNAMBIGUOUSLY UNDERSTOOD. MINOR OMISSIONS OR ERRORS IN THE DRAWINGS AND OR SPECIFICATIONS SHALL NOT EXCLUDE SAID CONTRACTOR FROM COMPLETING THE PROJECT AND IMPROVEMENTS IN ACCORDANCE WITH THE INTENT OF THESE DOCUMENTS. THE BIDDERS SHALL BEAR THE RESPONSIBILITY OF NOTIFYING (IN WRITING) THE ARCHITECTS/ENGINEERS OF ANY OMISSIONS OR ERRORS. DISCREPANCIES PRIOR TO THE SUBMISSION OF CONTRACTOR'S PROPOSAL. IN THE EVENT OF DISCREPANCIES THE CONTRACTOR SHALL PRICE THE MORE COSTLY OR EXTENSIVE WORK, UNLESS DIRECTED OTHERWISE.

T-Mobile

T-MOBILE WEST LLC

“ANCHOR PROJECT”

NOTE:
CONTRACTOR TO VERIFY THAT POWER
UPGRADE (RED PEAK WEST POWER
UPGRADE DATED 7-27-20) IS TO BE
COMPLETED BEFORE
ANY NEW TECHNOLOGIES ARE
POWERED UP

LEGEND

- A — ANTENNA CABLE (ABOVE GROUND)
- T — TELEPHONE SERVICE (ABOVE GROUND)
- E — POWER SERVICE (ABOVE GROUND)
- G — GROUND RING (ABOVE GROUND)
- A — ANTENNA CABLE (BURIED)
- T — TELEPHONE SERVICE (BURIED)
- E — POWER SERVICE (BURIED)
- G — GROUND RING (BURIED)

PROJECT SUMMARY

SITE NAME: RED PEAK WEST
 SITE NUMBER: SC09320A
 SITE ADDRESS: 2000 FIRST AVE
 SPARKS, NEVADA 89431
 SITE CONTACT: BUDD WUELFING
 (530) 863-7342
 OWNER: DESERT VIEW COMMERCIAL PROPERTIES, LLC
 1032 DUCK HILL ROAD
 CARSON CITY, NEVADA 89704
 APPLICANT: T-MOBILE WEST LLC
 APPLICANTS ADDRESS: 1755 CREEKSIDE OAKS DRIVE
 SUITE 190
 SACRAMENTO, CALIFORNIA 95833
 ASSESSORS PARCEL NUMBER(S): 502-025-008

SHEET INDEX

T-1	TITLE SHEET
A-1	SITE PLAN
A-1.1	ENLARGED SITE PLAN
A-2	ELEVATION
A-3.1	DETAILS
A-3.2	DETAILS
E-1	ELECTRICAL SHEET
E-2	GROUNDING SHEET

CONTACTS

R.E. ENGINEERING:
 T-MOBILE WEST LLC
 1755 CREEKSIDE OAKS DRIVE
 SUITE 190
 SACRAMENTO, CALIFORNIA 95833

CONSTRUCTION MANAGER:
 BUDD WUELFING
 1755 CREEKSIDE OAKS DRIVE, SUITE 190
 SACRAMENTO, CALIFORNIA 95833
 (530) 863-7342

CODE COMPLIANCE

ALL WORK AND MATERIALS SHALL BE PERFORMED AND INSTALLED IN ACCORDANCE WITH THE CURRENT EDITION OF THE FOLLOWING CODES AS ADOPTED BY THE LOCAL GOVERNING AUTHORITIES. NOTHING IN THESE PLANS IS TO BE CONSTRUED TO PERMIT WORK NOT CONFORMING TO THESE CODES.

2018 INTERNATIONAL BUILDING CODE
 2018 INTERNATIONAL MECHANICAL CODE
 2017 NATIONAL ELECTRICAL CODE

VICINITY MAP

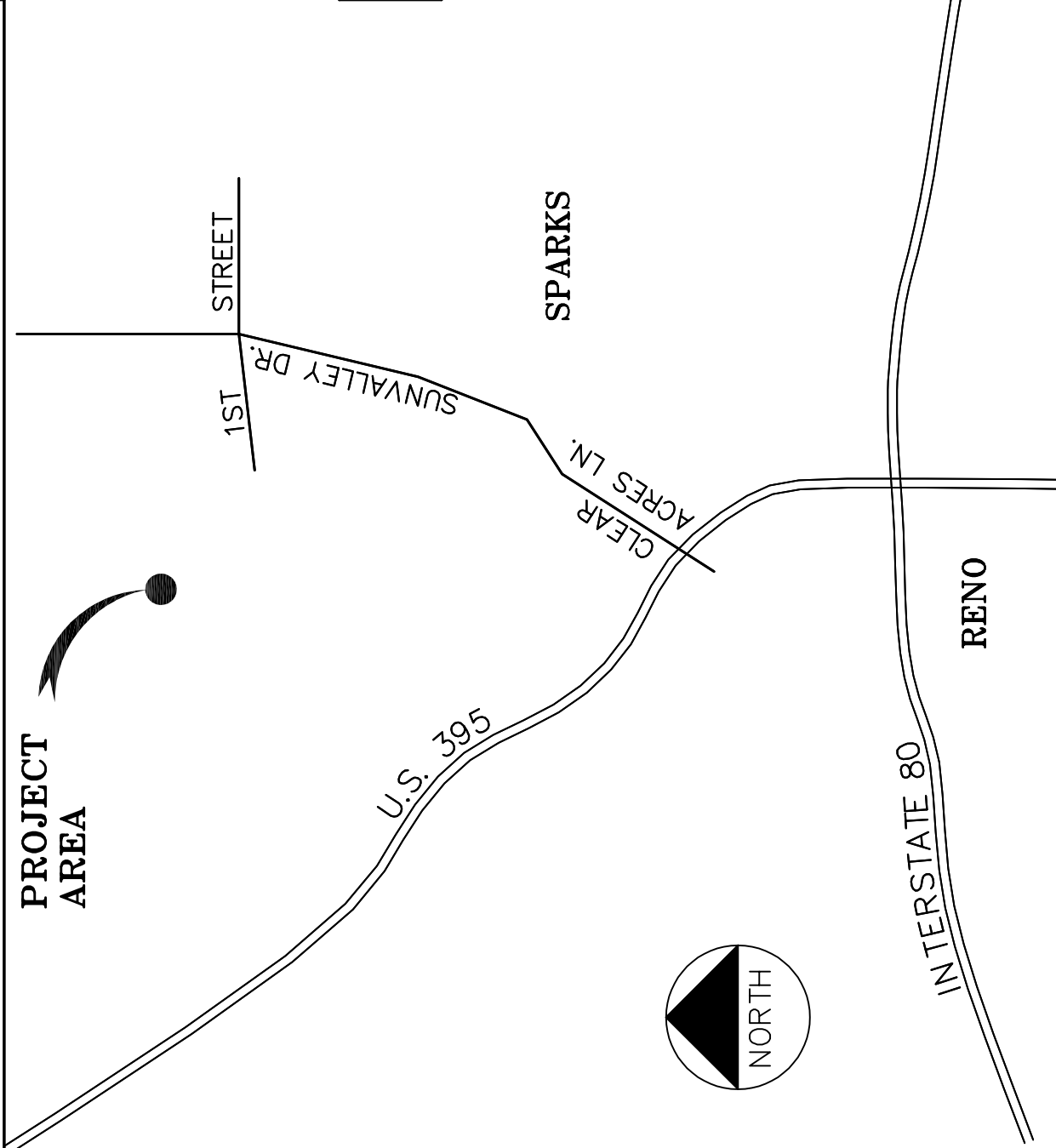

T-MOBILE PROPOSES TO:

- INSTALL NEW 40' MONOPOLE
- INSTALL (6) NEW ANTENNAS ON NEW ANTENNA MOUNTS
- INSTALL (4) NEW RRUS ON NEW ANTENNA MOUNTS
- INSTALL (1) NEW 6160 CABINET
- INSTALL (1) NEW B160 CABINET
- INSTALL (3) NEW HCS CABLES
- REMOVE (2) (E) ANTENNAS
- REMOVE (2) (E) TMAS
- REMOVE (3) (E) RRUS

RAN TEMPLATE; 67D5A997DB HYBRID

PROPRIETARY INFORMATION

THE INFORMATION CONTAINED IN THIS SET OF DRAWINGS IS PROPRIETARY BY NATURE. ANY USE OR DISCLOSURE OTHER THAN THAT WHICH RELATES TO PEAK SITE-COM IS STRICTLY PROHIBITED

CLIENT:

T-Mobile
T-MOBILE WEST LLC
1755 Creekside Oaks Drive, Suite 190 • Sacramento, CA 95833

PROJECT INFORMATION:

RED PEAK WEST

2000 FIRST AVE
SPARKS, NEVADA 89431

BY: _____

REV #	DATE	DESCRIPTION	BY
1	7-15-20	90% CDS	ALP
2	8-3-20	100% CDS	VRT
3	8-6-20	rev 100% CDS	VRT

COORDINATING ENGINEER:

Peek Site-Com

12852 Earhart Ave, Suite 101
Auburn, California 95602
Phone (530) 885-6160

E-Mail info@peeksitecom.com

SEAL:

SITE # _____ CHK: _____ DRAWN BY: _____

SC09320 ... ALP

SHEET TITLE:

TITLE SHEET

SHEET NUMBER: _____ REVISION: _____

T-10

CONCRETE PAD SPECS.

CONCRETE MIX DESIGNS SHALL CONFORM TO IBC SECTION 1903
PORTLAND CEMENT SHALL BE TYPE II AND CONFORM TO ASTM C150
CONCRETE SHALL HAVE A MIN. 28 DAY COMPRESSIVE STRENGTH OF
2500 PSI. #4 REBAR AT 12" OC. REINFORCEMENT FOR SLAB ON
GRADE.

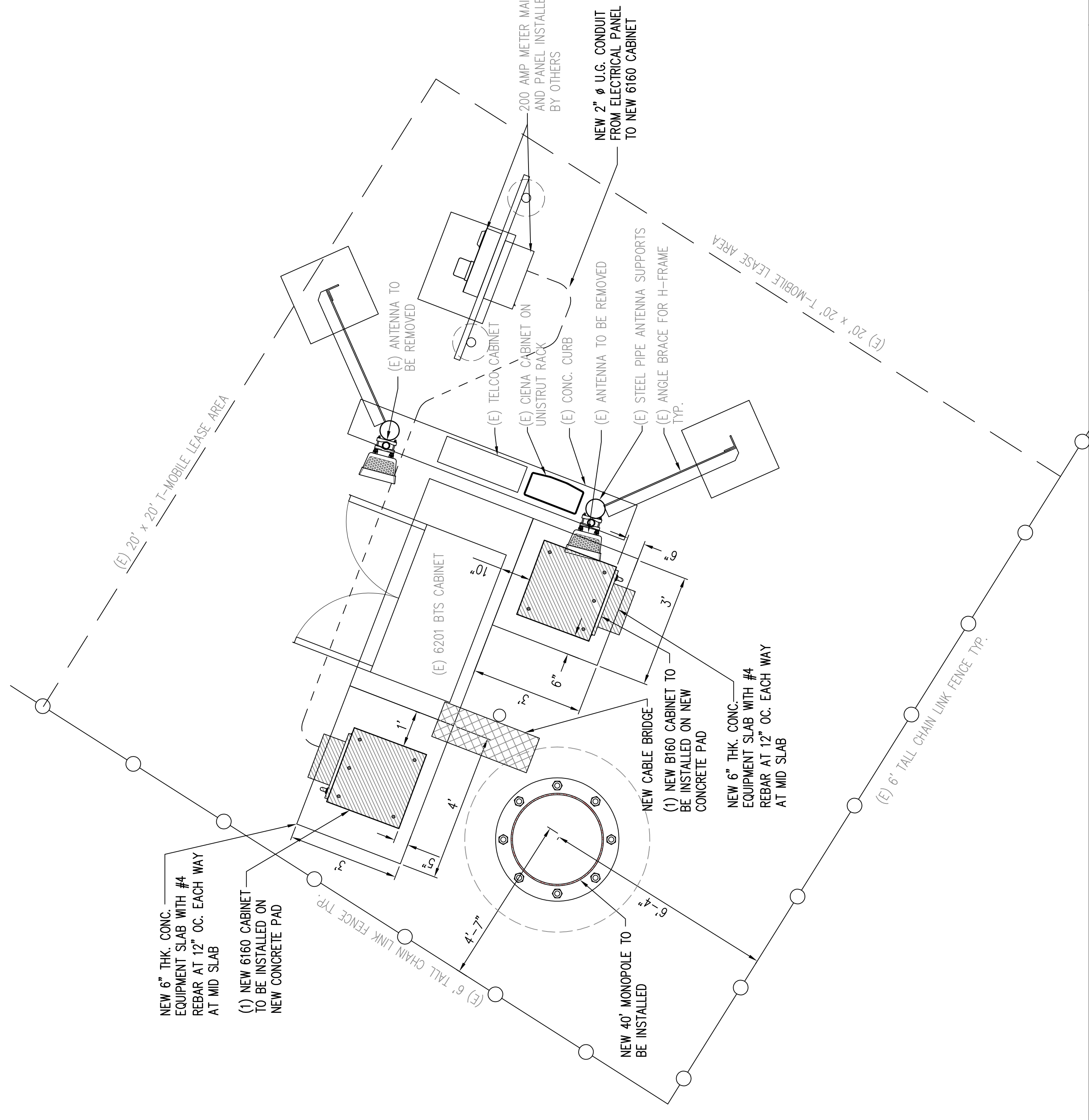

ENLARGED SITE PLAN



0 2' 4' 8' 12'
SCALE: 1/4"=1'-0"

1

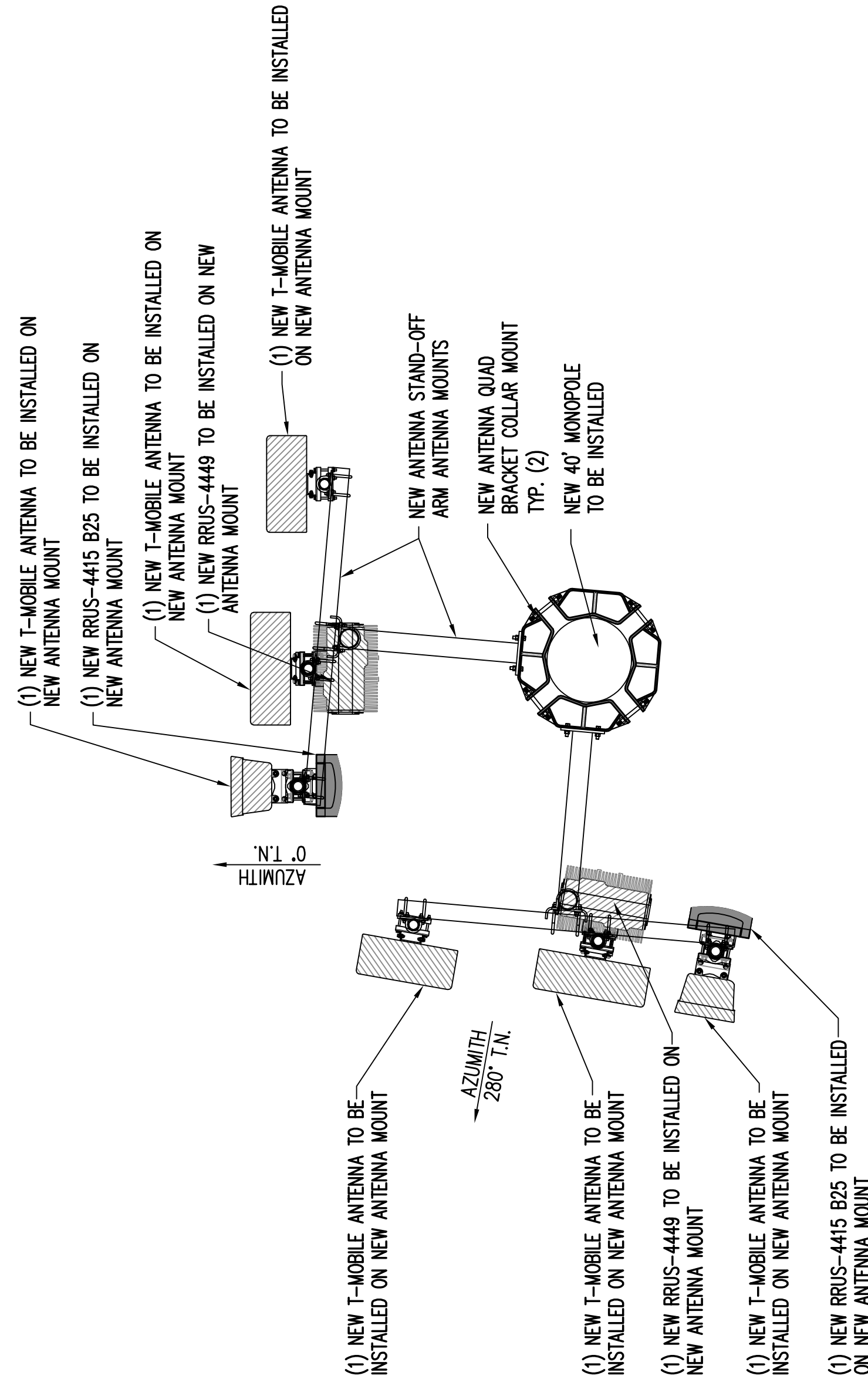

(P) ANTENNA LAYOUT



SCALE: N.T.S.

2

PROPRIETARY INFORMATION
THE INFORMATION CONTAINED IN THIS SET OF DRAWINGS IS PROPRIETARY BY NATURE. ANY USE OR DISCLOSURE OTHER THAN THAT WHICH RELATES TO PEAK SITE-COM IS STRICTLY PROHIBITED

CLIENT:

T-Mobile
T-MOBILE WEST LLC
1756 Creekside Oaks Drive, Suite 100 • Sacramento, CA 95833

PROJECT INFORMATION:

RED PEAK WEST

2000 FIRST AVE
SPARKS, NEVADA 89431

BY: ALP

DESCRIPTION: 90% CDS

1 7-15-20

2 8-3-20 100% CDS

3 8-6-20 rev 100% CDS

COORDINATING ENGINEER:

Peek Site-Com

12852 Earhart Ave, Suite 101
Auburn, California 95602
Phone (530) 885-6160
E-Mail info@peeksitcom.com

SEAL:

SITE #: ...

CHK.: ALP

DRAWN BY:

SHEET TITLE:

ENLARGED SITE PLAN

SHEET NUMBER: REVISION:

A-1.1.10

PROPRIETARY INFORMATION

THE INFORMATION CONTAINED IN THIS SET OF DRAWINGS IS PROPRIETARY BY NATURE. ANY USE OR DISCLOSURE OTHER THAN THAT WHICH RELATES TO PEAK SITE-COM IS STRICTLY PROHIBITED

CLIENT:

T-Mobile

T-MOBILE WEST LLC
1765 Creekside Oaks Drive, Suite 190 • Sacramento, CA 95833

PROJECT INFORMATION:

RED PEAK WEST

2000 FIRST AVE
SPARKS, NEVADA 89431

REV. DATE DESCRIPTION BY:

1	7-15-20	90% CDS	ALP
2	8-3-20	100% CDS	VRT
3	8-6-20	rev 100% CDS	VRT

COORDINATING ENGINEER:

Peek Site-Com

12852 Earhart Ave. Suite 101
Auburn, California 95602
Phone (530) 885-6160
E-Mail info@peeksitecom.com

SEAL:

SITE # CHK. DRAWN BY:

SC09320 ... ALP

SHEET TITLE:

DETAILS

SHEET NUMBER: REVISION:

A-3.2 0

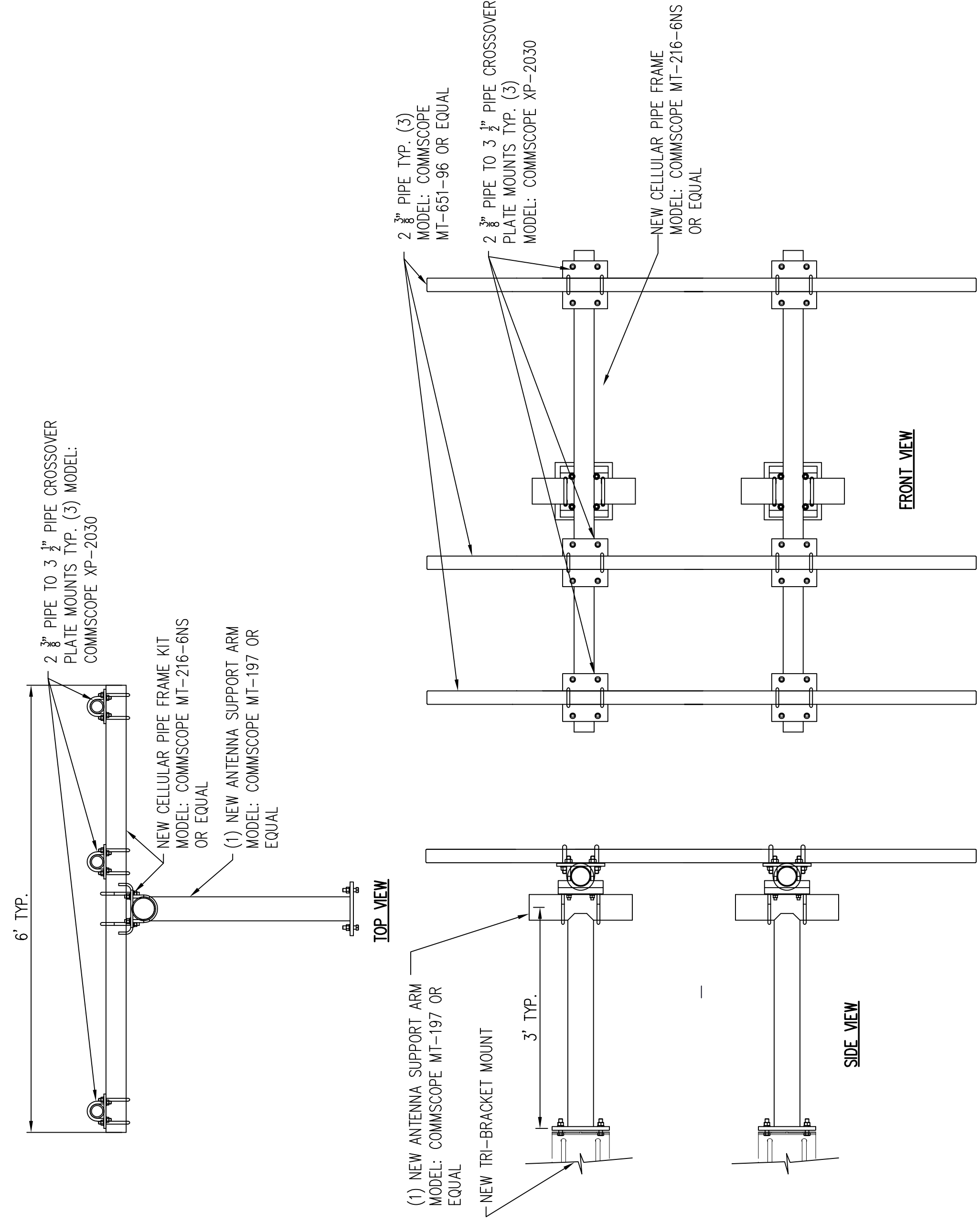

ITEM	PART NO.	DESCRIPTION	QTY.	WEIGHT
1	MCRH030403	1030-4 Ringmount Veldent	4	24.82 LBS
2	MT-384-20	3/4" X 20" GALV THREADED ROD	8	2.48 LBS
3	5WL-06	3/4" GALV LOCK WASHER	16	0.09 LBS
4	6N-06	3/4" GALV HEX NUT	16	0.33 LBS

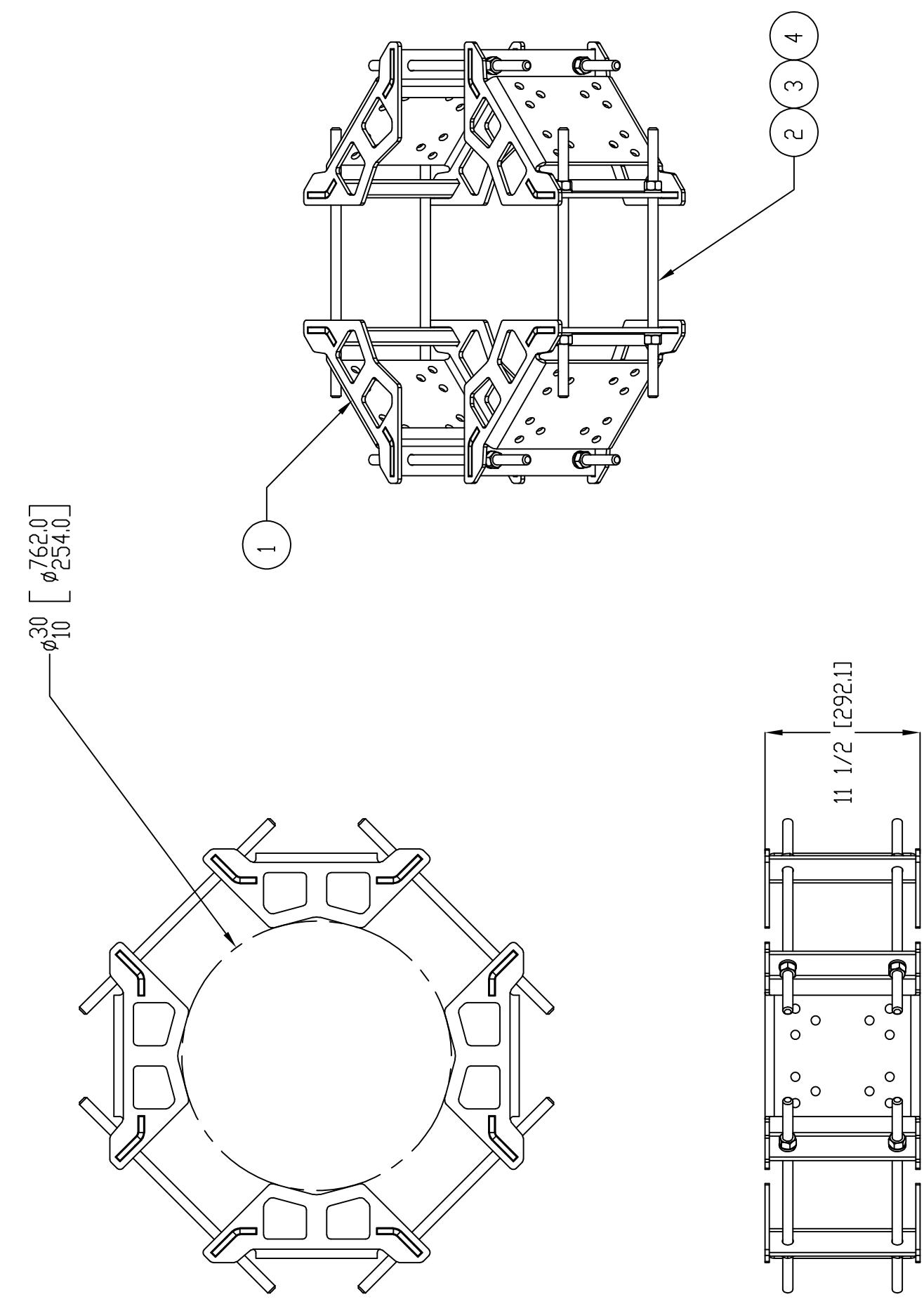

LOAD CENTER "PPC" PANEL SCHEDULE

PANEL DESCRIPTION: 120/240 VOLTS 1 PHASE 3 WIRE SURFACE WIRING: X MAIN BUS: X
WITH SEPARATE GROUND BUS 20, 200A

NO.	LOAD DESCRIPTION	ΦA	ΦB	AMP/POLE	AMP/POLE	ΦA	ΦB	LOAD DESCRIPTION	NO.
1	NEW 6160 CABINET	8500	-	100/2	-	-	-	SPACE	2
3	-	-	8500	20/1	-	500	-	RECEPT	4
5	(E) BITS CABINET	10000	-	100/2	-	-	-	SPACE	6
7	-	-	-	-	-	-	-	SPACE	8
9	SPARE	-	-	20/1	-	-	-	SPACE	10
11	SPACE	-	-	-	-	-	-	SPACE	12
13	SPACE	-	-	-	-	-	-	SPACE	14
15	SPACE	-	-	-	-	-	-	SPACE	16
17	SPACE	-	-	-	-	-	-	SPACE	18
19	SPACE	-	-	-	-	-	-	SPACE	20
21	SPACE	-	-	-	-	-	-	SPACE	22
23	SPACE	-	-	-	-	-	-	SPACE	24
25	SPACE	-	-	-	-	-	-	SPACE	26
27	SPACE	-	-	-	-	-	-	SPACE	28
29	SPACE	-	-	-	-	-	-	SPACE	30

TOTAL CONNECTED (DISPOSED) VA: 37500L
 (THE ASSUMED CONTINUOUS VALUES OF 125% OF ADJ. LOAD FOR ALL MOTOR, MOTOR & HEATERS IN 6160 UNITS)
 TOTAL CONNECTED (FUTURE) VA: 37500L
 (THE ASSUMED CONTINUOUS VALUES OF 125% OF ADJ. LOAD FOR ALL MOTOR, MOTOR & HEATERS IN 6160 UNITS)
 TOTAL CONNECTED (P+F) VA: 37500L
 (THE ASSUMED CONTINUOUS VALUES OF 125% OF ADJ. LOAD FOR ALL MOTOR, MOTOR & HEATERS IN 6160 UNITS)
 DEMAND LOAD VA: 37500L
 125% ≥ 100%

NEW 100/2 CB. TO BE INSTALLED FOR NEW 6160 CABINET

PANEL SCHEDULE

SCALE: N.T.S. **1**

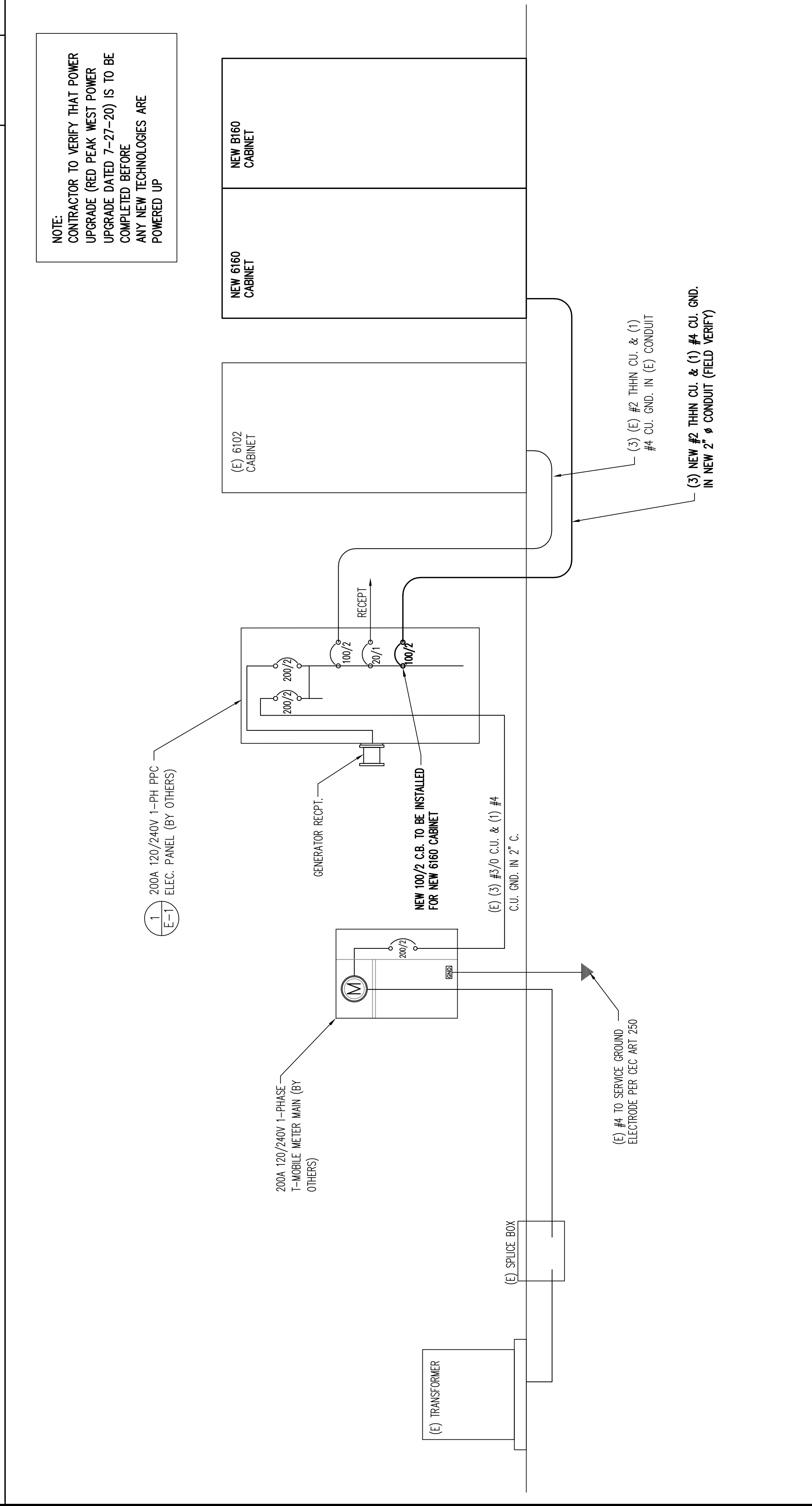

PARTIAL ONE LINE DIA.

SCALE: N.T.S. **2**

ELECTRICAL LEGEND

NEW	EXISTING	PANEL BOARD, SURFACE MOUNTED
□	▨	DRY TYPE TRANSFORMER
⊠	⊡	METER
⊞	⊞	CIRCUIT BREAKER
⊞	⊞	NON-FUSIBLE DISCONNECT SWITCH, MOUNTED 54" A.F.F.
⊞	⊞	FUSIBLE DISCONNECT SWITCH, MOUNTED 54" A.F.F.
⊞	⊞	TRANSIENT VOLTAGE SURGE SUPPRESSOR WITH BUILT-IN FUSES, SURFACE MOUNTED
⊞	⊞	DUPLEX OUTLET, SURFACE MOUNTED, 20 AMPS, 125 VOLTS, SINGLE PHASE
⊞	⊞	JUNCTION BOX, SURFACE MOUNTED 18" A.F.F.
Sk		KEYED SWITCH, SURFACE MOUNTED
⊞		WALL MOUNTED, ENCLOSED, AND GASKETED INDUSTRIAL INCANDESCENT FIXTURE WITH ONE 100 AMP LAMP MOUNT 72" A.F.F.
⊞		EXPOSED WIRING
⊞		HOME RUNS, MINIMUM #10 + 1#10G IN 3/4" CONDUIT U.O.N.
A.F.F.		ABOVE FINISHED FLOOR
U.O.N.		UNLESS OTHERWISE NOTED
WP		WEATHERPROOF
GFI		GROUND FAULT INTERRUPTER

PROPRIETARY INFORMATION

THE INFORMATION CONTAINED IN THIS SET OF DRAWINGS IS PROPRIETARY BY NATURE. ANY USE OR DISCLOSURE OTHER THAN THAT WHICH RELATES TO PEAK SITE-COM IS STRICTLY PROHIBITED

T-Mobile

T-MOBILE WEST LLC
 1755 Creekside Oaks Drive, Suite 190 • Sacramento, CA 95833

PROJECT INFORMATION:

RED PEAK WEST
 2000 FIRST AVE
 SPARKS, NEVADA 89431

REV.	DATE	DESCRIPTION	BY
1	7-15-20	90% CDS	ALP
2	8-3-20	100% CDS	VRT
3	8-6-20	rev 100% CDS	VRT

COORDINATING ENGINEER:

Peek Site-Com
 12852 Earhart Ave., Suite 101
 Auburn, California 95602
 Phone (530) 885-6160
 E-Mail: info@peeksitecom.com

SEAL:

SITE # _____ CHK: _____ DRAWN BY: _____

SCO9320 ... ALP

SHEET TITLE:

SHEET NUMBER: **ELECTRICAL SHEET**

REVISION: **E-10**

Existing



Proposed



view from Ranger Road looking east at site

Existing



Proposed



view from Opal Bluff Drive looking southeast at site

Existing



Proposed



view from Flint Springs Drive looking south at site

Existing



Proposed



Proposed T-Mobile
Installation

view from W. Golden Valley Road looking southwest at site



SC09320A Red Peak West
2000 First Avenue, Sparks, NV
Photosims Produced on 9-11-2020

Existing



Proposed



Proposed T-Mobile Installation Not Visible

view from W. First Avenue looking northwest at site

Existing



Proposed



view from Dandini Boulevard looking northwest at site

SC09320A Red Peak West
2000 First Avenue, Sparks, NV
Photosims Produced on 9-11-2020

Existing



Proposed



view from Dandini Boulevard looking northwest at site



SC09320A Red Peak West
2000 First Avenue, Sparks, NV
Photosims Produced on 9-11-2020

Existing



Proposed



view from Dandini Boulevard looking northeast at site

SC09320A Red Peak West
2000 First Avenue, Sparks, NV
Photosims Produced on 9-11-2020

